

T 8004-GR EN

Series SMS · SMS MG-1 and SMS MG-7 Pneumatic Control Valves

Type 251GR Globe Valve

ANSI version



Application

Control valve for process engineering applications with high industrial requirements

Nominal size	NPS ½ to 8
Pressure rating	Class 150 to 900
Temperatures	-58 to 1112 °F (-50 to +600 °C)

Type 251GR Globe Valve operated with

- Type 3271 Pneumatic Actuator (SMS MG-1 Control Valve)
- Type 3277 Pneumatic Actuator (SMS MG-7 Control Valve) for integral positioner attachment

Special features

- Plug and cage trim replaceable in the field
- Body made of cast steel
- Body made of cast stainless steel
- Soft seal
- Metal seal
- High-performance metal seal
- Balanced to handle high differential pressures

Optional with RFID tags with unique identification according to DIN SPEC 91406.

The control valves with their modular design can be equipped with various accessories:

Positioners, limit switches, solenoid valves and other valve accessories according to IEC 60534-6-1¹⁾ and NAMUR recommendation (see Information Sheet ▶ T 8350).

Versions

Operating temperature (medium temperature) with PTFE packing for temperatures from -20 to 482 °F (-29 to +250 °C), with graphite packing in combination with insulating section from -58 to 1112 °F (-50 to +600 °C) or with bellows seal (independent from the packing version) up to 842 °F (+450 °C), nominal size NPS ½ to 8, Class 150 to 900 (see Table 1)

- **SMS MG-1** (Fig. 1) · Type 251GR Globe Valve and Type 3271 Actuator with 350 to 2800 cm² actuator area (see Data Sheets ▶ T 8310-1, ▶ T 8310-2 and ▶ T 8310-3)
- **SMS MG-7** · Type 251GR Globe Valve and Type 3277 Actuator with 350 to 750v2 cm² actuator area for integral positioner attachment (see Data Sheet ▶ T 8310-1)

¹⁾ Accessories required. See associated actuator documentation.



Fig. 1: SMS MG-1: Type 251GR Globe Valve with Type 3271 Pneumatic Actuator

Further versions

- **Valve plug with pressure balancing**
- **Additional handwheel** · See Data Sheet ▶ T 8310-1
- **Type 251GR Valve with Type 3273 Hand-operated Actuator** · For valves with max. 30 mm rated travel and side-mounted handwheel for travel > 30 mm · See Data Sheet ▶ T 8312
- **SMS MG-TP Electric Control Valve** · On request
- Version with **clamped-in** or **screwed-in seat** or with **cage trim**
- **Version with insulating section for high temperatures**
- **Version with bellows seal**

Principle of operation of version with clamped-in/screwed-in seat

The medium flows through the valve in the direction indicated by the arrow. The valve plug determines the cross-sectional area of flow.

The valves can be equipped with a flow divider ST 1 (see Data Sheet ► T 8081) for noise reduction.

Pressure balancing must be used when high pressures or differential pressures act on the plug.

Fig. 2 and Fig. 3 show configuration examples.

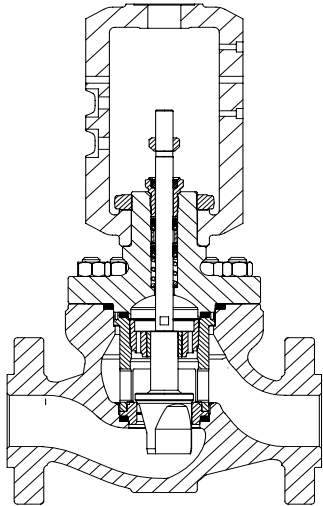

Fig. 2: Type 251GR Globe Valve operated with clamped-in seat

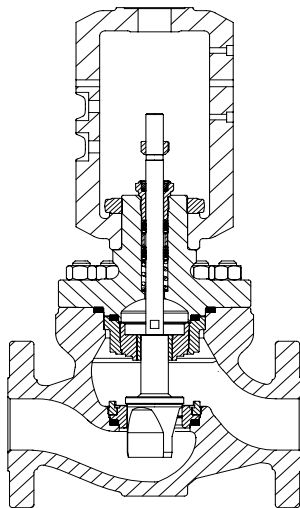

Fig. 3: Type 251GR Globe Valve operated with screwed-in seat

Principle of operation of cage version

The medium flows through the valve as indicated by the arrow on the valve body. A change in the pneumatic signal acting on the actuator changes the piston travel and how far the valve is opened as a result. The piston position and cage design determine the released cross-section and the resulting flow rate.

Fig. 4 shows a configuration example.

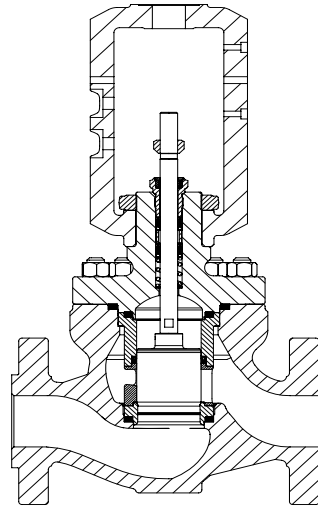

Fig. 4: Type 251GR Globe Valve with cage trim

All the trims shown in Fig. 2 to Fig. 4 are interchangeable in the field without any revisions necessary to the pressure-bearing or pressure-retaining parts.

Fail-safe position

Depending on how the springs are arranged in the pneumatic actuator (see Data Sheets ► T 8310-1, ► T 8310-2 and ► T 8310-3), the valve has two different fail-safe positions that become effective when the supply air fails.

- **Actuator stem extends (fail-close)**
The valve closes when the supply air fails.
- **Actuator stem retracts (fail-open)**
The valve opens when the supply air fails.

Differential pressures

The permissible differential pressures can be found in the Information Sheet ► T 8000-4.

Table 1: Technical data for Type 251GR

Material	Cast steel A216 WCC	Cast steel A217 WC6	Cast stainless steel A351 CF8M
Nominal size and pressure rating	Class 150: NPS ½ to 8 Class 300: NPS ½ to 8 Class 600: NPS ½ to 8 Class 900: NPS ½ to 6 ³⁾		
Type of end connections	RF and RTJ according to ASME B16.5		
Flanges	On request		
Welding ends	On request		
Seat-plug seal	Metal seal · High-performance metal seal		
Characteristic	Equal percentage · Linear · Mod. linear · On/off		
Rangeability	50:1		
RFID tag (optional)	Application range according to the technical specifications and the explosion protection certificates. Documents ► www.samsongroup.com > Products > Electronic nameplate		
Conformity	CE		
Temperature ranges ²⁾ in °F (°C) · Permissible operating pressures acc. to pressure-temperature diagrams (see Information Sheet ► T 8000-2)			
Body without insulating section	-20 to 482 (-29 to +250) with PTFE packing · Up to +425 (+797) with graphite packing		
Body with insulating section	-20 to 797 (-29 to +425)	-20 to +986 (-29 to +530)	-58 to +1112 (-50 to +600)
Body with bellows seal	-20 to 797 (-29 to +425)	-20 to +986 (-29 to +530)	-58 to +842 (-50 to +450)
Trim ¹⁾	Metal seal	-58 to +1112 (-50 to +600)	
	Balanced with PTFE	-58 to +482 (-50 to +250)	
RFID tag (optional)	Max. permissible temperature at the RFID tag: 185 (85)		
Leakage class according to ANSI/FCI 70-2			
Trim	Metal seal	Standard: IV · High-performance metal seal: V	
	Balanced, metal seal	With PTFE (standard): IV · High-performance metal seal: V	

¹⁾ Only in combination with suitable body material

²⁾ The temperature limits (in °F and °C) are not directly converted temperatures.

³⁾ Class 900 only for version with clamped-in seat or cage trim

Table 2: Materials

Standard version		Cast steel A216 WCC		Cast steel A217 WC6		Cast stain- less steel A351 CF8M	
Body		A216 WCC		A217 WC6		A351 CF8M	
Valve bonnet		A216 WCC		A217 WC6		A351 CF8M	
Plug stem		316/316L or XM-19-H					
Seal ring for balanced plug		PTFE with carbon · Graphite					
Guide bushing		440C		440C		2.4610	
Packing		PTFE packing loaded by internal or external springs or adjustable graphite packing					
Body gasket		Spiral-wound gasket, graphite/316L					
Version with screwed-in seat and plug	Plug ³⁾	410 ²⁾	440C ¹⁾	316/316L ²⁾	410 ²⁾	440C ¹⁾	316/316L ²⁾
	Seat	410 ²⁾	440C ¹⁾	316/316L ²⁾	410 ²⁾	440C ¹⁾	316/316L ²⁾
	Seat fastening	CA6NM-B		CA6NM-B		316/316L	
Version with clamped-in seat and plug	Plug ³⁾	410 2 ²⁾	440C ¹⁾	316/316L ²⁾	410 2 ²⁾	440C ¹⁾	316/316L ²⁾
	Seat	410 2 ²⁾	440C ¹⁾	316/316L ²⁾	410 2 ²⁾	440C ¹⁾	316/316L ²⁾
	Seat fastening	A217 WC 9		A217 WC 9		CF8M	
Version with piston and cage	Piston	410 2 ¹⁾	440C ¹⁾	316/316L ^{4) 5)}	410 2 ¹⁾	440C ¹⁾	316/316L ^{4) 5)}
	Cage	410 2 ¹⁾	440C ¹⁾	316/316L	410 2 ¹⁾	440C ¹⁾	316/316L
	Seat	410 2 ¹⁾	440C ¹⁾	316/316L ²⁾	410 2 ¹⁾	440C ¹⁾	316/316L ²⁾
	Cylinder	410 2 ¹⁾	440C ¹⁾	316/316L	410 2 ¹⁾	440C ¹⁾	316/316L

¹⁾ Heat treated

²⁾ Also Stellite®-faced facing

³⁾ Plug made of Stellite® 6 (up to seat bore Ø ≤55 mm) available

⁴⁾ Guiding surface with hard chrome plating

⁵⁾ Guiding surface also Stellite® faced when the facing is Stellite®-faced

Table 3: K_{VS} coefficients for version with plug · **Equal percentage or linear**Terms for control valve sizing according to IEC 60534, Parts 2-1 and 2-2: $FL = 0.95$, $XT = 0.75$ **Table 3.1:** Versions with **screwed-in seat (equal percentage or linear)**

K_{VS}	0.26	0.43	0.65	0.95	1.7	2.6	4.3	6.9	13	21	32	47	74	110	190	273	400	700
C_V	0.3	0.5	0.75	1.1	2	3	5	8	15	24	37	54	85	128	220	315	465	810
K_{VS-1}	-	-	-	-	1.6	2.3	3.9	6.2	12	19	29	42	66	100	171	245	363	630
C_{V-1}	-	-	-	-	1.8	2.7	4.5	8.2	14	22	34	49	76	116	200	284	420	730
Seat bore in mm	4/8	6/8	6/8	6/8	12	12	24	24	27	33	42	55	70	85	110	130	170	228
Travel in mm	15	15	15	15	15	15	15	15	15	19	19	30	38	38	60	60	60	90

Table 3.2: Versions without flow divider (screwed-in seat)

K_{VS}	0.26	0.43	0.65	0.95	1.7	2.6	4.3	6.9	13	21	32	47	74	110	190	273	400	700
C_V	0.3	0.5	0.75	1.1	2	3	5	8	15	24	37	54	85	128	220	315	465	810
NPS	DN																	
1/2	15	•	•	•	•	•	•	•										
1	25			•	•	•	•	•	•									
1 1/2	40					•	•	•	•	•	•							
2	50								•	•	•	•						
3	80										•	•	•	•				
4	100											•	•	•	•			
6	150													•	•	•	•	
8	200														•	•	•	•

Table 3.3: Versions with flow divider ST 1 (K_{VS-1}) (screwed-in seat)

K_{VS-1}	-	-	-	-	1.6	2.3	3.9	6.2	12	19	29	42	66	100	171	245	363	630
C_{V-1}	-	-	-	-	1.8	2.7	4.5	8.2	14	22	34	49	76	116	200	284	420	730
NPS	DN																	
1/2	15				•	•	•											
1	25				•	•	•	•	•									
1 1/2	40				•	•	•	•	•	•	•							
2	50								•	•	•	•						
3	80										•	•	•	•				
4	100											•	•	•	•			
6	150													•	•	•	•	
8	200														•	•	•	•

Table 3.4: Version with *clamped-in seat (equal percentage or linear)*

K _{Vs}	0.26	0.43	0.65	0.95	1.7	2.6	3.9	4.3	6.9	12	13	21	29	32	42	47	74	100	110	171	190	273	363	400	630	700
C _V	0.3	0.5	0.75	1.1	2	3	4.5	5	8	14	15	24	34	37	49	54	85	116	128	200	220	315	420	465	730	810
Seat bore in mm	4/8	6/8	6/8	6/8	12	12	24	24	24	27	27	33	42	42	55	55	70	85	85	110	110	130	170	170	228	228
Travel in mm	15	15	15	15	15	15	15	15	15	15	15	19	19	19	30	30	38	38	38	60	60	60	60	60	90	90

Table 3.5: Versions without flow divider (*clamped-in seat*)

K _{Vs}	0.26	0.43	0.65	0.95	1.7	2.6	3.9	4.3	6.9	12	13	21	29	32	42	47	74	100	110	171	190	273	363	400	630	700	
C _V	0.3	0.5	0.75	1.1	2	3	4.5	5	8	14	15	24	34	37	49	54	85	116	128	200	220	315	420	465	730	810	
NPS	DN																										
½	15	•	•	•	•	•	•	•																			
1	25			•	•	•	•		•	•	•																
1½	40				•	•			•	•		•	•	•													
2	50										•	•		•	•												
3	80													•		•	•	•									
4	100															•	•		•	•							
6	150																		•		•	•	•				
8	200																				•	•		•	•		

Table 4: Dimensions in inches and mm

Table 4.1: SMS MG-1 and SMS MG-7 Pneumatic Control Valve

Valve	NPS		½	1	1½	2	3	4	6	8
Length L Flange RF	Class 150	in	7.25	7.25	8.75	10	11.75	13.88	17.75	21.38
		mm	184	184	222	254	298	352	451	543
	Class 300	in	7.5	7.75	9.25	10.5	12.5	14.5	18.62	22.38
		mm	190	197	235	267	318	368	473	568
	Class 600	in	8	8.25	9.88	11.25	13.25	15.5	20	24
		mm	203	210	251	286	337	394	508	610
	Class 900	in	11.5	11.5	13.12	14.75	17.38	20.12	28.12	30.75
		mm	292	292	333	375	441	511	714	781
Length L Flange RTJ	Class 150	in	7.25	7.75	9.25	10.5	12.25	14.38	18.25	21.88
		mm	184	197	235	267	311	365	464	556
	Class 300	in	7.94	8.25	9.75	11.12	13.12	15.12	19.25	23
		mm	201	210	248	283	334	384	489	584
	Class 600	in	7.94	8.25	9.88	11.37	13.37	15.62	20.12	24.12
		mm	201	210	251	289	340	397	511	613
	Class 900	in	11.5	11.5	13.12	14.87	17.5	20.24	28.24	30.87
		mm	292	292	333	378	444	514	717	784
Length L Welding ends	Class 150 to 600	in	8	8.25	9.88	11.25	13.25	15.5	20	24
		mm	203	210	251	286	337	394	508	610
	Class 900	in	11	11	13	14.75	18.12	20.12	30.25	32.75
		mm	279	279	330	375	460	511	768	832
Height H4 Standard version	in	5.12	5.51	6.14	6.93	7.87	9.84	12.6	15.75	
	mm	130	140	156	176	200	250	320	400	
Height H4 With insulating section	in	8.86	8.86	10.04	11.42	12.4	14.76	20.87	24.02	
	mm	225	225	255	290	315	375	530	610	
Height H4 With bellows seal	in	On request	16.38	On request	18.27	22.05	22.64	33.9	On request	
	mm	On request	416	On request	464	560	575	861	On request	
H8 for actuator	350 cm ²	in	11.26	11.26	11.26	11.26	11.26	11.26	19.8	–
		mm	286	286	286	286	286	286	503	–
	350v2 cm ²	in	11.26	11.26	11.26	11.26	11.26	11.26	19.8	–
		mm	286	286	286	286	286	286	503	–
	355v2 cm ²	in	11.26	11.26	11.26	11.26	11.26	11.26	19.8	–
		mm	286	286	286	286	286	286	503	–
	750v2 cm ²	in	11.26	11.26	11.26	11.26	11.26	11.26	19.8	–
		mm	286	286	286	286	286	286	503	–
	1000 cm ²	in	13.43	13.43	13.43	13.43	13.43	13.43	19.8	19.8
		mm	341	341	341	341	341	341	503	503
	1400- 60 cm ²	in	13.43	13.43	13.43	13.43	13.43	13.43	19.8	19.8
		mm	341	341	341	341	341	341	503	503
	1400- 120 cm ²	in	–	–	–	20.71	20.71	20.71	23.15	23.15
		mm	–	–	–	526	526	526	588	588
	2800 cm ²	in	–	–	–	20.71	20.71	20.71	23.15	23.15
		mm	–	–	–	526	526	526	588	588
2x 2800 cm ²	in	–	–	–	20.71	20.71	20.71	23.15	23.15	
	mm	–	–	–	526	526	526	588	588	

Valve	NPS		1/2	1	1 1/2	2	3	4	6	8
H2 ¹⁾	Class 150	in	1.75	2.13	2.5	2.99	4.15	5.35	7.28	8.46
		mm	44.5	54	63.5	76	105.5	136	185	215
	Class 300 to 600	in	1.87	2.44	3.05	3.25	4.15	5.35	7.28	8.46
		mm	47.5	62	77.5	82.5	105.5	136	185	215
	Class 900	in	2.38	2.93	3.5	4.25	4.74	5.75	7.5	-
		mm	60.5	74.5	89	108	120.5	146	190.5	-

¹⁾ The H2 dimension is the distance from the middle of the flow path to the bottom of the valve body. The dimension up to the bottom of the flange may differ. It may be lower or higher. Flange standards (see Table 1).

Dimensional drawings

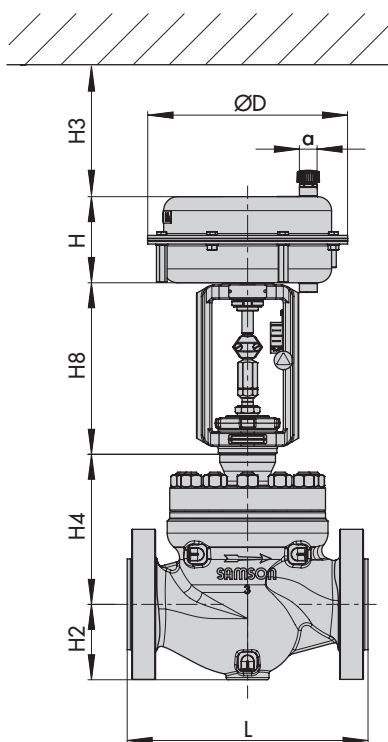

SMS MG-1 Control Valve

Type 251GR Valve with Type 3271 Pneumatic Actuator

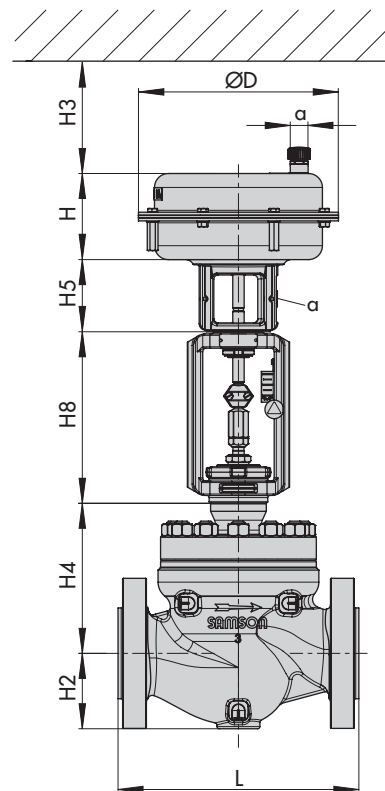

SMS MG-7 Control Valve

Type 251GR Valve with Type 3277 Pneumatic Actuator

Dimensional drawings

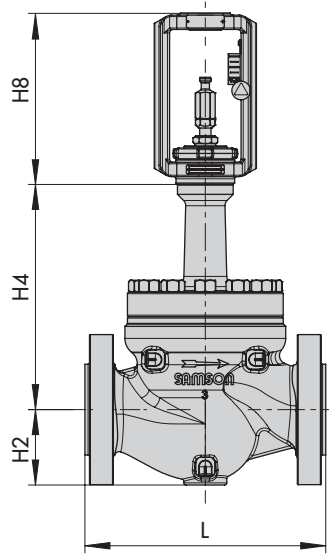

Type 251GR Valve with insulating section

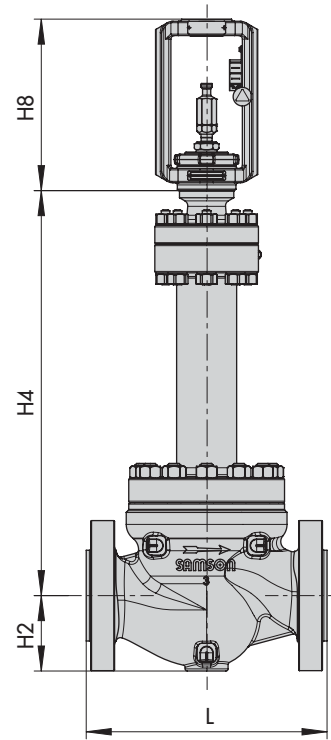

Type 251GR Valve with bellows seal

Table 4.2: Type 3271 and Type 3277 Pneumatic Actuators

Actuator area	cm ²	350	350v2	355v2	750v2	1000	1400-60	1400-120	2800	2 x 2800	
Diaphragm ØD	in	11.02	11.02	11.02	15.51	18.19	20.87	21.02	30.32	30.32	
	mm	280	280	280	394	462	530	534	770	770	
H ¹⁾	Type 3271	in	3.23	3.62	5.16	9.29	15.87	13.27	23.54	28.07	47.76
		mm	82	92	131	236	403	337	598	713	1213
	Type 3277	in	3.23	3.23	4.76	9.29	-	-	-	-	-
		mm	82	82	121	236	-	-	-	-	-
H3 ²⁾	in	4.33	4.33	4.33	7.48	24.02	24.02	25.59	25.59	25.59	
	mm	110	110	110	190	610	610	650	650	650	
H5	Type 3277	in	3.98	3.98	3.98	3.98	-	-	-	-	-
		mm	101	101	101	101	-	-	-	-	-
Thread	Type 3271	M30x1.5				M60x1.5			M100x2		
	Type 3277	M30x1.5				-	-	-	-	-	-
a	Type 3271	G 3/8 (3/8 NPT)	G 3/8 (3/8 NPT)	G 3/8 (3/8 NPT)	G 3/8 (3/8 NPT)	G 3/4 (3/4 NPT)	G 3/4 (3/4 NPT)	G 1 (1 NPT)	G 1 (1 NPT)	G 1 (1 NPT)	
a2	Type 3277	G 3/8	G 3/8	G 3/8	G 3/8	-	-	-	-	-	

¹⁾ Height including lifting eyelet or female thread and eyebolt according to DIN 580. Height of the swivel hoist may differ. Actuators up to 355v2 cm² without lifting eyelet or female thread

²⁾ Minimum clearance required to remove the actuator

Table 5: Dimensions in lbs and kg

Table 5.1: Type 251GR Valve with RF flanges according to ASME B16.5

Valve		NPS	½	1	1½	2	3	4	6	8
Standard version										
Valve ¹⁾ without actuator	Class 150	lbs (approx.)	20	29	37	64	101	148	298	511
		kg (approx.)	9	13	17	29	46	67	135	232
	Class 300	lbs (approx.)	22	33	46	68	112	174	355	589
		kg (approx.)	10	15	21	31	51	79	161	267
	Class 600	lbs (approx.)	22	33	49	75	128	225	470	820
		kg (approx.)	10	15	22	34	58	102	213	372
	Class 900	lbs (approx.)	33	46	66	119	194	298	681	-
		kg (approx.)	15	21	30	54	88	135	309	
Version with insulating section										
Valve ¹⁾ without actuator	Class 150	lbs (approx.)	24	33	44	68	115	168	355	589
		kg (approx.)	11	15	20	31	52	76	161	267
	Class 300	lbs (approx.)	24	35	51	75	128	196	417	672
		kg (approx.)	11	16	23	34	58	89	189	305
	Class 600	lbs (approx.)	26	37	53	82	132	231	500	851
		kg (approx.)	12	17	24	37	60	105	227	386
	Class 900	lbs (approx.)	37	51	71	123	198	304	712	-
		kg (approx.)	17	23	32	56	90	138	323	
Version with bellows seal										
Valve ¹⁾ without actuator	Class 150	lbs (approx.)	-	29	37	60	93	146	282	467
		kg (approx.)		13	17	27	42	66	128	212
	Class 300	lbs (approx.)	-	33	44	64	106	174	346	551
		kg (approx.)		15	20	29	48	79	157	250
	Class 600	lbs (approx.)	-	35	49	71	112	201	414	688
		kg (approx.)		16	22	32	51	91	188	312
	Class 900	lbs (approx.)	-	-	-	-	-	-	-	-
		kg (approx.)		-	-	-	-	-	-	-

¹⁾ The weights specified apply to a specific standard device configuration. Weights of other valve configurations may differ depending on the version (material, trim etc.).

Table 5.2: Type 3271 and Type 3277 Pneumatic Actuators

Actuator area		cm ²	350	350v2	355v2	750v2	1000	1400-60	1400-120	2800	2 x 2800
Weight ¹⁾	Without hand-wheel	lbs (approx.)	18	26	33	79	176	154	386	992	2095
		kg (approx.)	8	11.5	15	36	80	70	175	450	950
	Type 3271 With Type 3273 Hand-operated Actuator	lbs (approx.)	29	37	44	90	397	386	661 ^{2)/} 937 ³⁾	1268 ^{2)/} 1544 ³⁾	On request
		kg (approx.)	13	16.5	20	41	180	175	300 ^{2)/} 425 ³⁾	575 ^{2)/} 700 ³⁾	On request
	Type 3277 Without hand-wheel	lbs (approx.)	27	33	42	89	-	-	-	-	-
		kg (approx.)	12	15	19	40	-	-	-	-	-
Type 3277 With Type 3273 Hand-operated Actuator	lbs (approx.)	38	44	53	100	-	-	-	-	-	
	kg (approx.)	17	20	24	45	-	-	-	-	-	

¹⁾ The weights specified apply to a specific standard device configuration. Weights of other actuator configurations may differ depending on the version (material, number of actuator springs etc.).

²⁾ Side-mounted handwheel up to 80 mm travel

³⁾ Side-mounted handwheel above 80 mm travel

Selection and sizing of the valve

1. Calculate the C_v coefficient according to IEC 60534-6.
2. Select nominal size NPS and C_v coefficient.
3. Determine the permissible differential pressure from the Information Sheet ► T 8000-4.
4. Select the valve body material from Table 1 and Table 2 as well as from the pressure-temperature diagrams (see Information Sheet ► T 8000-2).
5. Select accessories from Table 1 and Table 2.

The following specifications are required on ordering:

Nominal size	NPS
Pressure rating	Class
Body material	See Table 2
Bonnet	Standard bonnet, insulating section or bellows seal
Type of end connections	Flanges/welding ends
Plug/piston	Standard or balanced Soft seal, metal seal or high-performance metal seal
Characteristic	Equal percentage, linear, mod. linear or on/off
Actuator	Type 3271 or Type 3277 (see Data Sheets ► T 8310-1, ► T 8310-2 and ► T 8310-3)
Fail-safe position	Fail-close or fail-open
Process medium	Density in lb/cu.ft or kg/m ³ and temperature in °F (°C)
Flow rate	lbs/h or kg/h or cu.ft/min or m ³ /h in standard or operating state
Pressure	p_1 and p_2 in psi (bar) (absolute pressure p_{abs}) (with minimum, normal and maximum flow rate)
RFID tag	Yes/No
Valve accessories	Positioner and/or limit switch

Associated Information Sheet	► T 8000-X
Associated Data Sheets for Pneumatic actuators	► T 8310-1 to -3
Associated Mounting and Operating Instructions	► EB 8004-GR