

T 5840 EN

Pneumatic Actuators

Type 2780-1

Type 2780-2

Application

Versatile actuators for use in heating, ventilation and air-conditioning systems as well as for mechanical engineering.

Actuator area: 120 cm²
Rated travel: 6, 12 or 15 mm

Special features

The Type 2780 Pneumatic Actuators are diaphragm actuators with internal compression springs. They are suitable for mounting on SAMSON Type 3213 and Type 3222 Globe Valves as well as Type 3226 and Type 3260 Three-way Valves.

The actuators have the following special features:

- Diaphragm cases made of die-cast aluminum
- Easily reversible direction of action
- Integral positioner attachment (Type 2780-2)
As a result, no external piping is required, regardless of the actuator's direction of action and the positioner.

Versions

- **Type 2780-1** (Fig. 1) · Pneumatic actuator
- **Type 2780-2** (Fig. 2) · Pneumatic actuator for direct attachment of a positioner

Ordering text

Type 2780-1/-2 Actuator

Fail-safe action: Actuator stem extends or retracts

6, 12 or 15 mm rated travel

Signal pressure range ... bar

Signal pressure connection 1/8 NPT/G 1/8



Fig. 1: Type 2780-1 Actuator

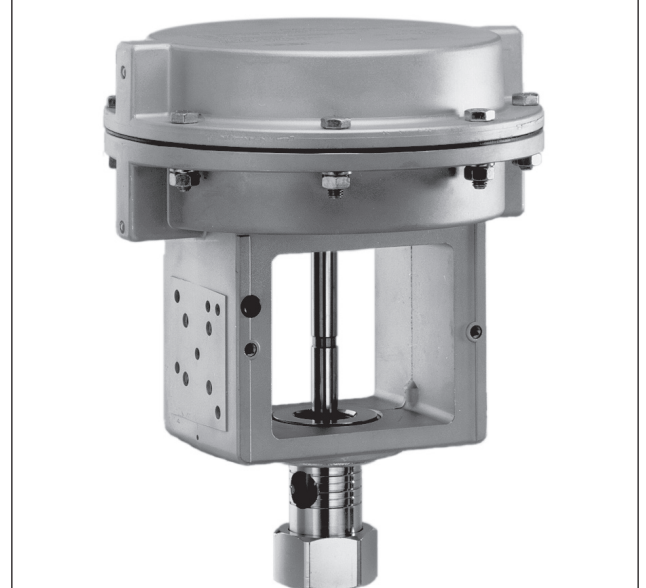

Fig. 2: Type 2780-2 Actuator

Principle of operation

The pneumatic actuator is operated by the forces acting on the diaphragm. The actuator spring force acts from the one side and the force of the signal pressure $F = p_{st} \times A$ on the other side. If the signal pressure changes causing the force on the diaphragm to change as well, the actuator stem moves. The actuator's direction of action depends on how the springs are arranged in the actuator.

Depending on which fail-safe action is to be used for the valve when the air supply fails, the springs in the actuator are installed either in the top or in the bottom diaphragm chamber (see Fig. 3 and Fig. 4). In both cases, the signal pressure is applied to the other diaphragm chamber.

In the Type 2780-1 Actuator, the signal pressure connections for both fail-safe actions are integrated into the diaphragm case. It is not possible to attach a positioner.

A positioner can be directly attached to a Type 2780-2 Actuator since the signal pressure is routed over inside ducts to the corresponding diaphragm chamber for both fail-safe actions. The signal pressure route is determined by a switchover plate installed according to the fail-safe action of the actuator and the the positioner's direction of action.

Fail-safe action

The actuator has two different fail-safe actions:

- **Actuator stem extends:** when the air supply fails, the spring force moves the actuator stem to the lower end position (see Fig. 3 and Fig. 4, left).
- **Actuator stem retracts:** when the air supply fails, the spring force causes the actuator stem to retract (see Fig. 3 and Fig. 4, right).

Technical data

Nominal size	DN	15 to 50 (G ½ to G 1)
Actuator area	cm ²	120
Max. supply pressure	bar	4
Fail-safe action		Reversible
Rated travel	DN 15 to 25 G ½ to G 1	mm 6
	DN 32 to 50	mm 12
Bench range	Type 2780-1	bar 0.4 to 1
	Type 2780-2	bar 0.4 to 2 ³⁾
Required supply pressure	bar	2.4
No. of springs		3 ¹⁾
Leakage rate	l _v /h	< 10
Signal pressure connection (Type 2780-1)		ISO 288/1, G ½; ½ NPT
Ambient temperature	°C	-35 to +80
Materials		
Body ²⁾		Aluminum GD-ALSi12
Diaphragm		NBR
Springs ²⁾		Spring wire C
External bolts		Chromated steel
Bushing		CW617N (CuZn40Pb)
Weight	Type 2780-1	kg 2
	Type 2780-2	kg 3.2

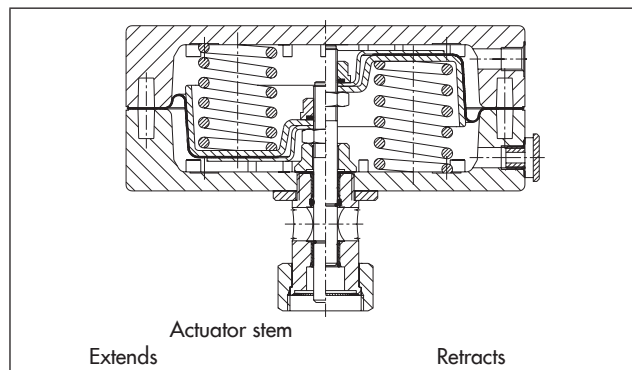

Fig. 3: Type 2780-1 Actuator

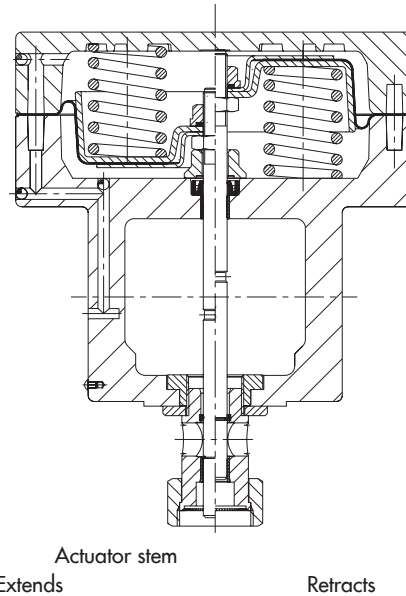

Fig. 4: Type 2780-2 Actuator

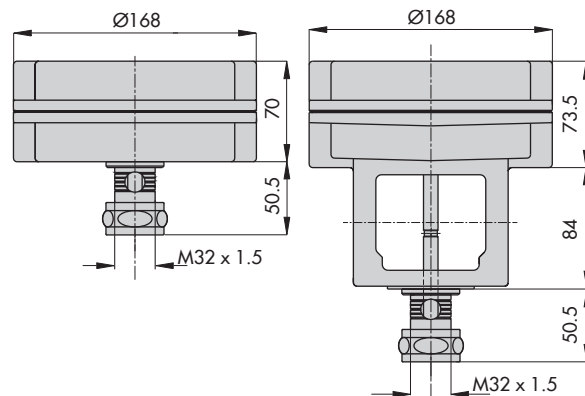

Fig. 5: Type 2780-1 (left) and Type 2780-2 (right) · Dimensions in mm

¹⁾ Six springs with 0.4 to 2 bar signal pressure range and 12 mm travel

²⁾ Not painted or surface treated

³⁾ See data sheets of control valves for further signal pressure ranges