

MOUNTING AND OPERATING INSTRUCTIONS



EB 3962-9 EN

Translation of original instructions



Type 3962-9 Solenoid Valve

Edition September 2019

CE Ex
certified

Note on these mounting and operating instructions

These mounting and operating instructions assist you in mounting and operating the device safely. The instructions are binding for handling SAMSON devices.

- For the safe and proper use of these instructions, read them carefully and keep them for later reference.
- If you have any questions about these instructions, contact SAMSON's After-sales Service (aftersaleservice@samsongroup.com).



The mounting and operating instructions for the devices are included in the scope of delivery. The latest documentation is available on our website at www.samsongroup.com > **Service & Support** > **Downloads** > **Documentation**.

Definition of signal words

DANGER

Hazardous situations which, if not avoided, will result in death or serious injury

WARNING

Hazardous situations which, if not avoided, could result in death or serious injury

NOTICE

Property damage message or malfunction

Note

Additional information

Tip

Recommended action

1	General safety instructions	4
1.1	Legal information.....	4
2	Markings on the device	5
2.1	Article code.....	5
2.2	Summary of explosion protection approvals.....	8
3	Design and principle of operation	9
3.1	Technical data	10
4	Accessories	15
5	Mounting and start-up	16
5.1	Mounting position.....	16
5.2	Ambient temperature.....	16
5.3	Wall mounting.....	16
5.4	Mounting on rotary actuators.....	17
5.5	Attachment to linear actuators using an adapter plate.....	17
5.6	Mounting on linear actuators using CrNiMo steel pipe fitting.....	18
6	Pneumatic connection	19
6.1	Sizing of the connecting line	19
6.2	Compressed air quality.....	19
6.3	Supply air	20
6.3.1	K_{VS} 2.0, 2.9 and 4.3.....	20
6.3.2	K_{VS} 1.4	20
7	Electrical connections	23
7.1	Electrical connection for type of protection Ex d.....	23
7.2	Cable entry	23
7.3	Manual override	23
8	Malfunctions	26

1 General safety instructions

- The device must be mounted, started up or operated only by trained and experienced personnel familiar with the product.
According to these mounting and operating instructions, trained personnel refers to individuals who are able to judge the work they are assigned to and recognize possible dangers due to their specialized training, their knowledge and experience as well as their knowledge of the applicable standards.
- Explosion-protected versions of this device must be operated only by personnel who has undergone special training or instructions or who is authorized to work on explosion-protected devices in hazardous areas.
- Any hazards that could be caused in the control valve by the process medium, the signal pressure or by moving parts are to be prevented by taking appropriate precautions.
- The supply pressure must not exceed the maximum permissible limit and must be limited by a pressure reducing valve, if necessary.
- If inadmissible motions or forces are produced in the pneumatic actuator as a result of the supply pressure, it must be restricted using a suitable supply pressure reducing station.
- Proper shipping and storage are assumed.

1.1 Legal information

The Type 3962 Solenoid Valve bears a CE marking. The declaration of conformity includes information about the applied conformity assessment procedure. The declarations of conformity are included in the Annex of these instructions.

2 Markings on the device

2.1 Article code

Solenoid valve	Type 3962-	x	x	x	x	x	x	x	x	x	x	x	x	x	x	x	x	x	x	x
Explosion protection																				
No explosion protection	0																			
Ex d	9																			
Nominal signal																				
24 V AC/DC	2 0																			
24 V DC	3 0																			
230 V AC/DC	4 0																			
230 V AC/110 V DC	5 0																			
115 V AC	6 0																			
115 V AC/DC	7 0																			
48 V AC	9 1																			
Type of protection																				
No explosion protection				0	0	0														
II 2 GD																				
ATEX Ex db IIC T* Gb				2	1	0														
Ex tb IIIC T* Db																				
IECEx Ex d IIC T*/DIP A21 T*				2	1	1														
NEPSI Ex d IIC T3-T6 Gb/DIP A21				2	1	2														
EAC 1 Ex d IIC T6/T5/T4/T3 Gb				2	1	3														
STCC II 2 G Ex d IIC Ta*				2	1	6														
II 2 D Ex tD A21 IP66 T*																				
ATEX II 2 G Ex emb II T5 II 2D Ex tD A21 IP65 T95°C				3	1	0														
Manual override																				
Without						0														
External pushbutton						2														
External switch						3														
External toggle switch						4														

Markings on the device

Solenoid valve	Type 3962-	x	x	x	x	x	x	x	x	x	x	x	x	x	x	x	x	x	x	x
Switching function																				
3/2-way function with spring-return mechanism	0																			
5/2-way function with spring-return mechanism ¹⁾	1																			
5/2-way function with two detent positions	2																			
5/3-way function with spring-centered mid-position (ports 2 and 4 closed)	3																			
5/3-way function with spring-centered mid-position (ports 2 and 4 supplied with air)	4																			
5/3-way function with spring-centered mid-position (ports 2 and 4 vented)	5																			
6/2-way function with spring-return mechanism	6																			
Attachment																				
NAMUR interface according to VDI/VDE 3845	0																			
Threaded connection for wall or pipe mounting	1																			
CNOMO interface, 30 mm (pilot valve as spare part)	2																			
K _{VS} ¹⁾																				
1.4 ³⁾	3																			
4.3	4																			
0.05 (pilot valve as spare part)	5																			
2.9 ⁴⁾	6																			
2.0	7																			
Enclosure material																				
Aluminum	0																			
Stainless steel	1																			
Pneumatic connection																				
G ¼	0																			
¼ NPT	1																			
G ½	2																			
½ NPT	3																			
Without threaded connections (pilot valve as spare part)	4																			
Pilot supply																				
Internal pilot supply for actuators for on/off service	0																			
External pilot supply for actuators for throttling service	1																			

Solenoid valve	Type 3962-	x	x	x	x	x	x	x	x	x	x	x	x	x	x	x	x	x	x	
Electrical connection																				
Cable entry M20x1.5 (female)	0	0																		
M20x1.5 cable gland, black polyamide	0	1																		
Adapter M20x1.5 (male) to ½ NPT (female)	1	2																		
Connector according to EN 175301-803, type A, black polyamide ⁵⁾	2	3																		
Degree of protection																				
IP 65 (Type 3962-0 and Type 3962-4)	1																			
IP 66 (Type 3962-9)	2																			
Ambient temperature ⁶⁾																				
-20 to +80 °C	0																			
-20 to +60 °C	1																			
-20 to +40 °C (max. +80 °C in T4)	2																			
-45 to +40 °C (max. +80 °C in T4)	3																			
Safety approval																				
Without										0										
SIL										1										
Special version																				
Without																		0	0	0

- 1) Not with NAMUR interface, K_{VS} 4.3
- 2) The air flow rate when $p_1 = 2.4$ bar and $p_2 = 1.0$ bar is calculated using the following formula:
 $Q = K_{VS} \times 36.22$ in m^3/h .
- 3) A distance plate is required with NAMUR interface/type of protection Ex d (see section 4 on page 15).
- 4) On request
- 5) The cable socket is not included in the scope of delivery. The degree of protection is only guaranteed when the cable socket and gasket underneath it are mounted.
- 6) The permissible ambient temperature of the solenoid valve depends on the permissible ambient temperature of the components, type of protection and temperature class.

2.2 Summary of explosion protection approvals

Type 3962-9			
Certification			Type of protection
ATEX	Number	CML15ATEX1119/X	II 2 GD Ex db IIC T* Gb Ex tb IIIC T* Db
	Date	2019-01-25	
EAC	Number	RU C DE 08.B.00764	1 Ex d IIC T6/T5/T4/T3 Gb
	Date	2015-02-10	
IECEX	Number	IECEX BAS 04.0028	Ex d IIC T*/DIP A21 T*
	Date	2013-07-02	
NEPSI	Number	GYJ13.1417X	Ex d II C T3-T6 Gb/DIP A21
	Date	2014-02-11	
STCC	Number	ZETC/32/2018	II 2 G Ex d IIC Ta* II 2 D Ex tD A21 IP66 T*
	Date	2018-05-07	
	Valid until	2021-05-06	

3 Design and principle of operation

The Type 3962-9 Solenoid Valve is suitable for controlling pneumatic linear or rotary actuators. The principle of operation is based on a solenoid plunger system with a downstream booster valve containing a diaphragm or spool actuator. The Type 3962-9 Solenoid Valve implements various way functions with K_{VS} 1.4 to 4.3 depending on the version.

3.1 Technical data

General data for pilot valve		
Type	3962-9	
Design	Solenoid and poppet valve with return spring	
Degree of protection	IP 66	
Material	Enclosure	Stainless steel, epoxy powder coated, red (spool housing) aluminum, hard anodized, black (CNOMO connection block)
	Internal parts	Stainless steel and brass
	Screws	Stainless steel
	Seals	FKM
Mounting orientation	Any	
Approx. weight	850 g	

Electrical data for pilot valve with type of protection flameproof enclosure Ex d					
Type		3962-930	3962-940	3962-960/-970	3962-980
Nominal signal	U_N	24 V DC ($\pm 10\%$)	230 V AC/DC ($\pm 10\%$) 50 to 60 Hz	115 V AC/DC ($\pm 10\%$) 50 to 60 Hz	24 V AC ($\pm 10\%$) 50 to 60 Hz
		Power consumption	Inrush	3 W	3 W
		3 W	3 W	5 VA/3 W	5 VA
Duty cycle		100 %			
Ambient temperature in temperature class (max. cable temperature)	T6	-60 to +40 °C	-	-	-
	T5	-60 to +55 °C	-60 to +55 °C	-60 to +55 °C (Type 3962-970 only)	-
	T4	-60 to +65 °C (85 °C) -60 to +80 °C (105 °C)	-	-60 to +40 °C (90 °C) (Type 3962-960 only)	-60 to +40 °C (90 °C)
	T3	-	-	-60 to +55 °C (105 °C) (Type 3962-960 only)	-60 to +55 °C (105 °C)
Port		Female thread M20x1.5			

Pneumatic data for pilot valve		
Type	3962-9	
Pilot supply	Medium	Instrument air
	Pressure	1.4 to 10 bar
Output signal	Same pressure as supply	
Air consumption	No air consumption	
K_{VS} coefficient	0.05	
Switching time	30 ms	
Control pressure connection	CNOMO interface	

Booster valve, actuated on one side, K_{VS} 4.3, with threaded connections			
Switching function	3/2-way function	5/2-way function	6/2-way function
K_{VS} ¹⁾ (direction of flow)	1.9 (4→3), 1.5 (3→4), 4.3 (3→5), 4.7 (5→3)		
Design	Poppet valve with diaphragm actuator, soft seated, with return spring		
Material	Enclosure	Aluminum, powder coated, gray beige RAL 1019 or stainless steel 1.4404	
	Diaphragms	Chloroprene rubber (-20 to +80 °C) or silicone rubber (-45 to +80 °C)	
	Seals	Chloroprene rubber (-20 to +80 °C) or silicone rubber (-45 to +80 °C)	
	Springs	Stainless steel 1.4310	
	Screws	Stainless steel 1.4571	
Actuation	Controlled on one side with a pilot valve		
Operating medium	Instrument air (free from corrosive substances) or nitrogen ²⁾ , Instrument air (free from corrosive substances), air containing oil or non-corrosive gases ³⁾		
Compressed air quality according to ISO 8573-1	Particle size and density: Class 4 · Oil content: Class 3 · Pressure dew point: Class 3 or at least 10 K below the lowest ambient temperature to be expected		
Max. operating pressure ⁴⁾	10.0 bar		
Output signal	Operating pressure		
Pneumatic connection	G 1/2 or 1/2 NPT		
Ambient temperature ⁵⁾	-20 to +80 °C, -45 to +80 °C		
Approx. weight	585 g	1100 g	

1) The air flow rate when $p_1 = 2.4$ bar and $p_2 = 1.0$ bar is calculated using the following formula:

$$Q = K_{VS} \times 36.22 \text{ in m}^3/\text{h.}$$

2) With internal pilot supply

3) With external pilot supply

4) To control the booster valve in the reversed direction of flow (3→4), the supply pressure must be higher than the operating pressure.

5) The permissible ambient temperature of the solenoid valve depends on the permissible ambient temperature of the components, types of protection and temperature class.

Markings on the device

Booster valve, actuated on one side, K_{VS} 2.0 or 4.3, with NAMUR interface			
Switching function	3/2-way function with exhaust air feedback		
K_{VS} ¹⁾ (direction of flow)	1.1 (4→3) 2.0 (3→5)	1.9 (4→3) 4.3 (3→5)	
Design	Poppet valve with diaphragm actuator, soft seated, with return spring		
Material	Enclosure	Aluminum, powder coated, gray beige RAL 1019 or stainless steel 1.4404	
	Diaphragms	Chloroprene rubber (-20 to +80 °C) or silicone rubber (-45 to +80 °C)	
	Seals	Chloroprene rubber (-20 to +80 °C) or silicone rubber (-45 to +80 °C)	
	Springs	Stainless steel 1.4310	
	Screws	Stainless steel 1.4571	
Actuation	Controlled on one side with a pilot valve		
Operating medium	Instrument air (free from corrosive substances) or nitrogen ²⁾ , Instrument air (free from corrosive substances), air containing oil or non-corrosive gases ³⁾		
Compressed air quality according to ISO 8573-1	Particle size and density: Class 4 · Oil content: Class 3 · Pressure dew point: Class 3 or at least 10 K below the lowest ambient temperature to be expected		
Max. operating pressure	10.0 bar		
Output signal	Operating pressure		
Pneumatic connection	Supply air	G ¼ or ¼ NPT and NAMUR interface ¼" ⁴⁾ with G ¾ / ¾ NPT	G ½ or ½ NPT and NAMUR interface ½" ⁴⁾
	Exhaust air	G ½ or ½ NPT and NAMUR interface ¼" ⁴⁾ with G ¾ / ¾ NPT	G ½ or ½ NPT and NAMUR interface ½" ⁴⁾
Ambient temperature ⁵⁾	-20 to +80 °C, -45 to +80 °C		
Approx. weight	1380 g	1500 g	

¹⁾ The air flow rate when $p_1 = 2.4$ bar and $p_2 = 1.0$ bar is calculated using the following formula:

$$Q = K_{VS} \times 36.22 \text{ in m}^3/\text{h}.$$

²⁾ With internal pilot supply

³⁾ With external pilot supply

⁴⁾ NAMUR interface according to VDI/VDE 3845

⁵⁾ The permissible ambient temperature of the solenoid valve depends on the permissible ambient temperature of the components, types of protection and temperature class.

Booster valve, actuated on one side, K_{VS} 1.4 or 2.9 ¹⁾ , with threaded connections or NAMUR interface		
Switching function	3/2-way function with exhaust air feedback	5/2-way function
K_{VS} ²⁾	1.4 or 2.9 ¹⁾	
Design	Spool, metal-to-metal seat, zero overlap, with return spring	
Material	Enclosure	Aluminum, powder coated, gray beige RAL 1019 or stainless steel 1.4404
	Seals	Silicone rubber
	Filter	Polyethylene
	Screws	Stainless steel 1.4571
Actuation	Controlled on one side with a pilot valve	
Operating medium	Instrument air (free from corrosive substances) or nitrogen ³⁾ , Instrument air (free from corrosive substances), air containing oil or non-corrosive gases ⁴⁾	
Compressed air quality acc. to ISO 8573-1	Particle size and density: Class 4 · Oil content: Class 3 · Pressure dew point: Class 3 or at least 10 K below the lowest ambient temperature to be expected	
Max. operating pressure	10.0 bar	
Output signal	Operating pressure	
Pneumatic connection	G 1/4 or 1/4 NPT and NAMUR interface 1/4" ⁵⁾ (K_{VS} 1.4) G 1/2 or 1/2 NPT and NAMUR interface 1/2" ⁵⁾ (K_{VS} 2.9)	
Ambient temperature ⁶⁾	-45 to +80 °C	
Approx. weight	485 kg (K_{VS} 1.4)	
	1760 kg (K_{VS} 2.9)	

¹⁾ On request

²⁾ The air flow rate when $p_1 = 2.4$ bar and $p_2 = 1.0$ bar is calculated using the following formula:

$$Q = K_{VS} \times 36.22 \text{ in m}^3/\text{h.}$$

³⁾ With internal pilot supply

⁴⁾ With external pilot supply

⁵⁾ NAMUR interface according to VDI/VDE 3845

⁶⁾ The permissible ambient temperature of the solenoid valve depends on the permissible ambient temperature of the components, types of protection and temperature class.

Markings on the device

Booster valve, actuated on both sides, K_{VS} 1.4, with threaded connections or NAMUR interface				
Switching function	5/2-way function with two detent positions	5/3-way function with spring-centered mid-position (ports 2 and 4 closed)	5/3-way function with spring-centered mid-position (ports 2 and 4 vented)	5/3-way function with spring-centered mid-position (ports 2 and 4 supplied with air)
K_{VS} ¹⁾	1.4			
Design	Spool, metal-to-metal seat, zero overlap			
Material	Enclosure	Aluminum, powder coated, gray beige RAL 1019 or stainless steel 1.4404		
	Seals	Silicone rubber		
	Filter	Polyethylene		
	Screws	Stainless steel 1.4571		
Actuation	Controlled on both sides with two pilot valves			
Operating medium	Instrument air (free from corrosive substances) or nitrogen ²⁾ , Instrument air (free from corrosive substances), air containing oil or non-corrosive gases ³⁾			
Compressed air quality acc. to ISO 8573-1	Particle size and density: Class 4 · Oil content: Class 3 · Pressure dew point: Class 3 or at least 10 K below the lowest ambient temperature to be expected			
Max. operating pressure	10.0 bar			
Output signal	Operating pressure			
Pneumatic connection	G ¼ or ¼ NPT and NAMUR interface ¼" ⁴⁾			
Ambient temperature ⁵⁾	-45 to +80 °C			
Approx. weight	685 g			

¹⁾ The air flow rate when $p_1 = 2.4$ bar and $p_2 = 1.0$ bar is calculated using the following formula:

$$Q = K_{VS} \times 36.22 \text{ in m}^3/\text{h.}$$

²⁾ With internal pilot supply

³⁾ With external pilot supply

⁴⁾ NAMUR interface according to VDI/VDE 3845

⁵⁾ The permissible ambient temperature of the solenoid valve depends on the permissible ambient temperature of the components, types of protection and temperature class.

4 Accessories

Designation	Order no.
M20x1.5 Ex d cable gland, made of brass (for 6.5 to 14 mm cable diameter)	8808-0200
Distance plate with NAMUR interface 1/4" on rotary actuators 1/4", including fastening screws and seals	
Aluminum, powder coated, gray beige RAL 1019	1400-9741
Stainless steel 1.4404	1402-0234
Adapter plate with NAMUR interface 1/4" on NAMUR rib (G 1/4)	1400-6751
Adapter plate with NAMUR interface 1/4" on NAMUR rib (1/4 NPT)	1400-9924
Support for NAMUR rib including fastening screw (required when a positioner or limit switch is additionally mounted on the linear actuator, DN 15 to 80)	1400-5905
Vent filter	
Filter made of polyethylene, G 1/4 connection, degree of protection IP 54	8504-0066
Filter made of polyethylene, G 1/2 connection, degree of protection IP 54	8504-0068

5 Mounting and start-up

i Note

The mounting accessories (fastening screws, washers and O-rings) are included in the scope of delivery.

5.1 Mounting position

Any mounting position may be used. The following applies concerning the installation:

- Mount the solenoid valve in such a way that the M20x1.5 threaded connection and vent plugs face downward (in cases where this is not possible, mount it in the horizontal position).
- On mounting, make sure that 300 mm or more clearance is kept above the enclosure cover.

5.2 Ambient temperature

The permissible ambient temperature is -20 to $+40$ °C.

Refer to the EC type examination certificate CML15ATEX1119/X for the permissible ambient temperature range for use in hazardous areas.

5.3 Wall mounting

Type 3962-9XXXXXXX13 and

Type 3962-9XXXXXXX14

To mount the devices, insert screws through the holes.

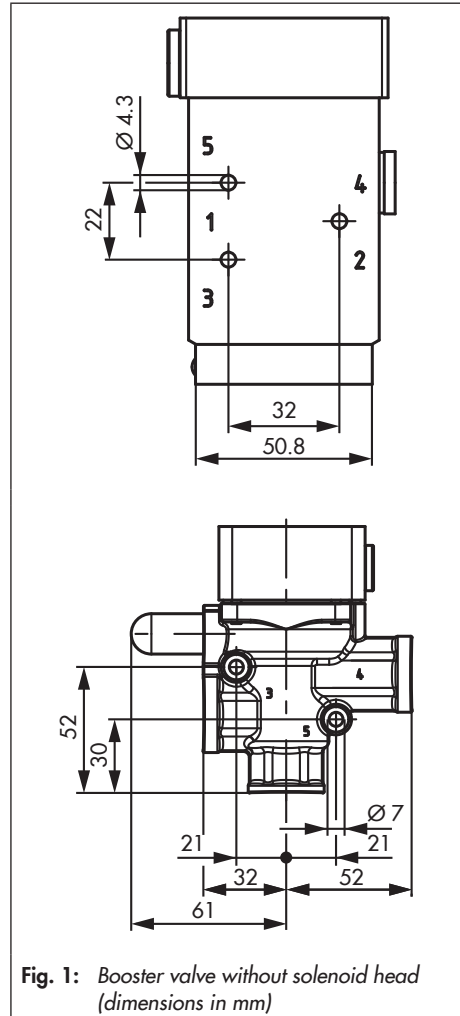

Fig. 1: Booster valve without solenoid head (dimensions in mm)

5.4 Mounting on rotary actuators

Type 3962-9XXXXXXX0

These devices can be mounted on rotary actuators with NAMUR interface (Fig. 2).

Before mounting, check that two O-rings are seated properly. Use a coded grub screw to determine the direction of action of the rotary actuator at the connecting flange. Use two screws to mount the device.

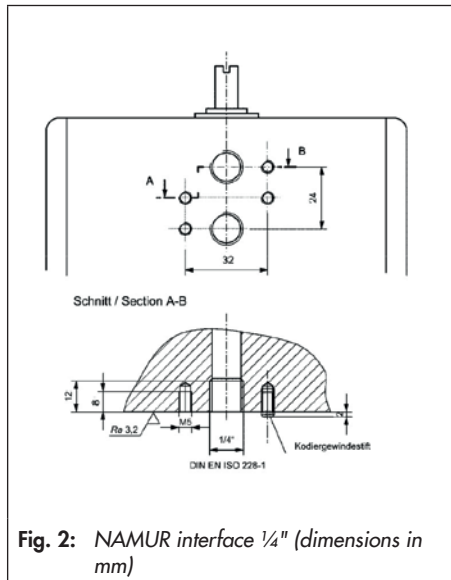

Fig. 2: NAMUR interface 1/4" (dimensions in mm)

5.5 Attachment to linear actuators using an adapter plate

Type 3962-9XXXXXXX0

These devices can be mounted on linear actuators with a NAMUR rib using an adapter plate (Fig. 3). When positioners or limit switches are also to be mounted on the linear actuator (DN 15 to 80), a support (1400-5905) is required (see section 4).

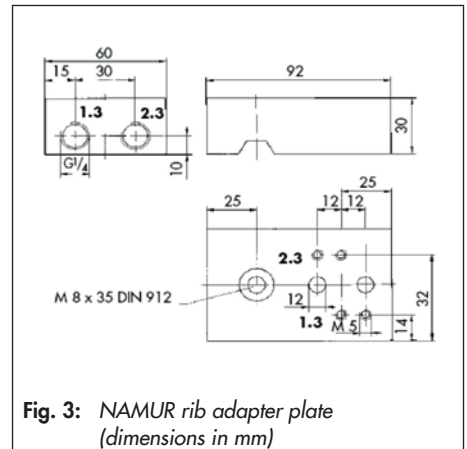

Fig. 3: NAMUR rib adapter plate (dimensions in mm)

5.6 Mounting on linear actuators using CrNiMo steel pipe fitting

Type 3962-9XXXXXX013X0 and
Type 3962-9XXXXXX014X2

These devices can be mounted on linear actuators, e.g. SAMSON Type 3271 or 3277 Actuators, using a CrNiMo steel pipe fitting (Fig. 4). See Mounting and Operating Instructions EB 8310-x for details on how to mount SAMSON actuators. Depending on the actuator size, the screw fitting consists either of two screw fittings with coupling nuts or an extension pipe with screw fitting and coupling nut.

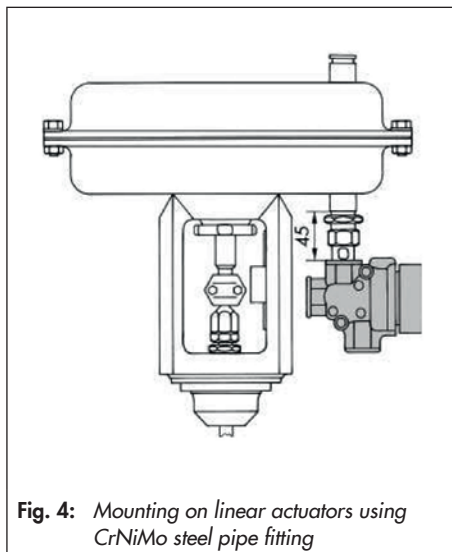

Fig. 4: Mounting on linear actuators using CrNiMo steel pipe fitting

Actuator area	Port	Order no.
80/175/240	G ¼ / G ¼	1400-6759
350/355/700/750	G ⅜ / G ¼	1400-6761
	G ⅜ / G ¼	1400-6735
1000/1400-60	G ¼ / G ½	1400-6736
1400-120/2800	G 1 / G ½	1400-6737

6 Pneumatic connection

⚠ WARNING

Risk of injury due to high pressure inside device.

Prior to performing repair and maintenance work on the device, depressurize the connecting lines.

The air connections are designed as threaded holes with G 1/4 (1/4 NPT) or G 1/2 (1/2 NPT) thread depending on the device version.

- ➔ Run and attach the connecting lines and screw joints according to good professional practice.
- ➔ Check the connecting lines and screw joints for leaks and damage at regular intervals and repair them.
- ➔ The K_{VS} coefficient of an upstream pressure reducing valve must be at least 1.6 times larger than the K_{VS} coefficient of the device.

Port labeling K_{VS} 2.0 and 4.3

Inscription	Function
4	Supply air
9	External pilot supply
3/5	Output

Port labeling K_{VS} 1.4 and 2.9

Inscription	Function
1	Supply air
9	External pilot supply
2/4 and 3/5	Output

6.1 Sizing of the connecting line

Refer to the table below for the minimum required nominal size of the connecting line at the port 4 of the enclosure.

The specifications apply to a connecting line shorter than 2 m. Use a larger nominal size for lines longer than 2 m.

Port	9	4
Pipe ¹⁾	6x1 mm	12x1 mm
Hose ²⁾	4x1 mm	9x3 mm

¹⁾ Outside diameter x Wall thickness

²⁾ Inside diameter x Wall thickness

6.2 Compressed air quality

With internal pilot supply over port 4 (delivered status):

- ➔ Instrument air (free from corrosive substances), 1.4 to 8 bar

With external pilot supply over port 9

- ➔ Instrument air (free from corrosive substances), air containing oil or non-corrosive gases with 0 to 8 bar

Compressed air quality according to ISO 8573-1		
Particle size and quantity	Oil content	Pressure dew point
Class 4	Class 3	Class 3
$\leq 5 \mu\text{m}$ and $1000/\text{m}^3$	$\leq 1 \text{ mg}/\text{m}^3$	$-20 \text{ }^\circ\text{C}/10 \text{ K}$ below the lowest ambient temperature to be expected

6.3 Supply air

In the delivered state, the supply air is fed internally over port **4**, if not specified otherwise.

- On mounting the solenoid valve on rotary or linear actuators fitted with positioners, the supply must be changed to an external pilot supply over port **9**.

To change to an external supply over port **9**, proceed as follows:

6.3.1 K_{VS} 2.0, 2.9 and 4.3

- Loosen the cap screw on the connection plate and remove plate 1 and turnable gasket 2.
- Turn the turnable gasket 2 by 90°. The tip of gasket 2 must rest in the plate cut-out marked '9'.
- Fasten plate 1 and turnable gasket 2 to the connection plate.

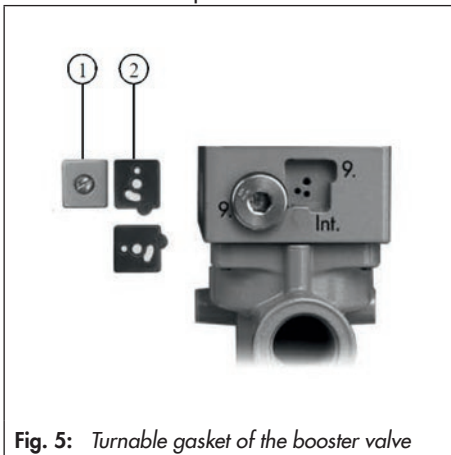

Fig. 5: Turnable gasket of the booster valve

6.3.2 K_{VS} 1.4

- Undo both hexagonal socket head screws (Fig. 6) and remove the black head. Make sure that the two black O-rings on the CNOMO interface do not get damaged (Fig. 7).



Fig. 6: Type 3962-4 Solenoid Valve, K_{VS} 1.4

- Undo the two hexagonal socket head screws (Fig. 7) and carefully remove the CNOMO interface.

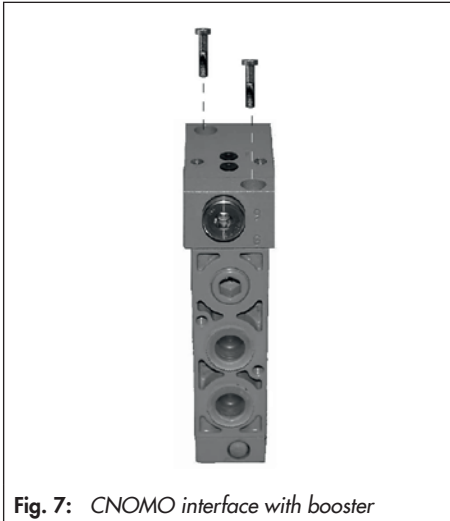

Fig. 7: CNOMO interface with booster

Make sure that the gaskets on the booster valve and CNOMO interface do not get damaged.

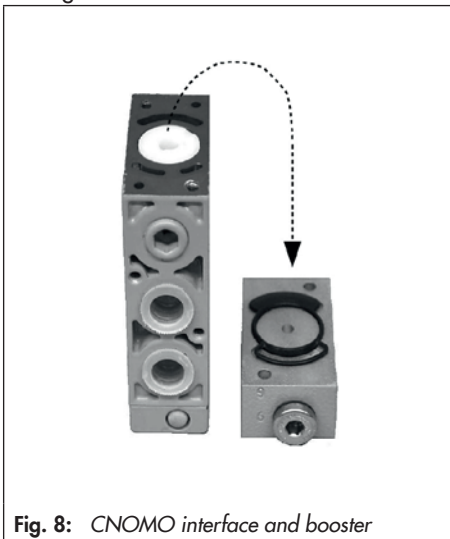

Fig. 8: CNOMO interface and booster

Internal air supply:

Do not seal the marked hole with the black turnable gasket (Fig. 9, left).

External pilot supply:

Seal the marked hole with the black turnable gasket (Fig. 9, right).

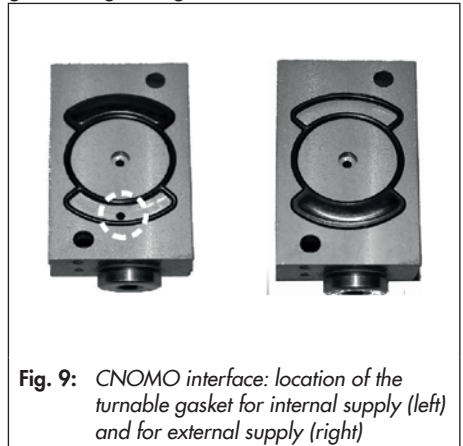

Fig. 9: CNOMO interface: location of the turnable gasket for internal supply (left) and for external supply (right)

- ➔ Carefully place the CNOMO interface onto the booster valve. Make sure that all gaskets are seated properly on the booster valve (if a gasket is missing, the entire Type 3962 Solenoid Valve must be replaced with a new device).

Pneumatic connection

Observe direction on installation:

The port 9 (external pilot supply) of the CNOMO interface must be located on the same side as port 1 (supply) or port 3 (exhaust) of the booster valve.

- Use the two hexagonal socket head screws to fasten the CNOMO interface (Fig. 7).
- Carefully place the red solenoid head onto the CNOMO interface. Make sure that the two openings of the red solenoid head are seated properly on the gaskets of the CNOMO interface (if a gasket is missing, the entire Type 3962 Solenoid Valve must be replaced with a new device). Make sure it is installed in the correct direction.
- Use the two hexagonal socket head screws to fasten the black solenoid head (Fig. 6).

7 Electrical connections

⚠ DANGER

For electrical installation, observe the relevant electrotechnical regulations and the accident prevention regulations that apply in the country of use. In Germany, these are the VDE regulations and the accident prevention regulations of the employers' liability insurance.

The degree of protection IEC 60529: 1989 is only guaranteed when the enclosure cover is mounted and the connections have been properly mounted.

The following regulations apply to installation in hazardous areas: EN 60079-14 (VDE 0165, Part 1) Explosive Atmospheres – Electrical Installations Design, Selection and Erection.

7.1 Electrical connection for type of protection Ex d

Connect the devices using suitable cable entries or conduit systems that comply with EN 60079-1 Explosive Atmospheres – Part 1: Equipment Protection by Flameproof Enclosures "d", Clauses 13.1 and 13.2 and for which a separate test certificate is available.

Do not use cable glands and blanking plugs of simple construction.

Install the connecting cable properly so that it is protected against mechanical damage. Include the devices in the on-site equipotential bonding system.

7.2 Cable entry

Refer to enclosed operating and maintenance instructions of the solenoid Ex II 2 GD.

7.3 Manual override

The devices can be optionally fitted with a manual override to allow the device to be manually operated when a nominal signal is not available.



Montage und Wartung des Ex II 2 GD (EExd IIC T3-6) Magneten Installation et maintenance – Ex II 2 GD (EExd IIC T3-6) Electrovanne

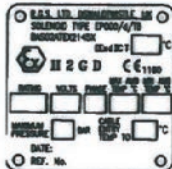
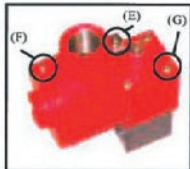
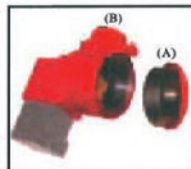

(D)

Montage

Montage dieses Magneten bitte nur durch Fachpersonal.

- 1) M30 Anschlußkappe (A) entfernen.
- 2) Elektrische Leitung durch Rohreingang (B) führen.
- 3) Elektrische Leitungsenden mit zweipoligem Anschlußbüch (C) verbinden. Beachten, daß diese Anschlüsse als polaritätsempfindlich markiert sein können, je nach dem, welcher Typ geliefert wurde. Sicherstellen, daß – wo markiert – korrekte Polarität verbunden wird, da der Magnet bei falscher Polarität beschädigt werden kann.
- 4) Erdeverbindungen wie benötigt mit internem Erdpunkt (D) oder externem Erdpunkt (E) herstellen.
- 5) Nach Baueingangs der elektrischen Anschlüsse wieder M30 Anschlußkappe (A) montieren und Sicherungsschraube (F) anziehen.

Wichtig: Beide Gewindeverbindungen an das Gehäuse sind Flammenwege und ein integrales Teil des Ex II 2 G Gehäuses. Sicherstellen, daß beide sicher angezogen sind bevor der Magnet erregt wird.

Montage sollte in Übereinstimmung mit IEC 79-14 vorgenommen werden sowie etwaigen relevanten nationalen Vorschriften.

Dieses Gerät ist geeignet für den Einsatz in Gefahrgutbereichen bis und einschließlich Cat. 2 und in zahlreichen Spannungen und T-Klassen verfügbar. Weitere Einzelheiten im RGS Katalog.

Schutz vor gefährlichen Atmosphären und anderen Gefahren

Magnetgehäuse hergestellt aus rostfreiem Stahl mit Epoxy-Deckschicht. Dieser Magnet darf nicht in Umgebungen installiert werden, die mit dem Apparatsetz reagieren und Explosionen verursachen oder das Schutzkonzept beeinflussen.

Dieses Gerät wurde entwickelt und hergestellt, um gegen andere Gefahren, wie in Paragraph 1.2.7 Anhang II der ATEX-Anweisung 549/EC festgelegt, zu schützen.

Das Gerät nicht aggressiven Substanzen aussetzen.

Reparatur/Überholung

Der Magnet ist nicht geeignet für die Reparatur oder Überholung im Feld. Zur Reparatur muß das Gerät an RGS zurückgeschickt werden.

Für die meisten Pneumatik-Spindelventile, an die das Magnetventil montiert ist, sind Reparatur-Sätze verfügbar. Der komplette Magnet-Apparatsetz kann vom Spindelventil abgebaut bzw. wieder an das Spindelventil montiert werden, ohne Beeinträchtigung des Magneten.



(F)

Installation

L'installation de cette electrovanne ne doit être effectuée que par du personnel agréé et compétent.

- 1) Enlever le couvercle du bornier M30 (A)
- 2) L'alimentation électrique doit être faite par l'entrée de conduit (B).
- 3) Connecter les fils de l'alimentation électrique au bornier (C). Noter que les bornes du bornier peuvent être marquées avec polarité, dépendant du modèle. Si c'est le cas, assurez-vous que la polarité est respectée. L'electrovanne peut être endommagée si la polarité nécessaire est inversée.
- 4) Connecter le fil de terre au point de terre interne (D) ou externe (E) comme requis.
- 5) Après avoir fini les connexions électriques, remettre en place le couvercle du bornier M30 (A), bien visser et serrer les vis de sécurité (F).

Nota importante: Les deux parties de vis d'obturer sont des passages de flammes et font partie intégrante de l'assemblage Ex II G. Il faut s'assurer que les deux parties soient proprement vissées avant de brancher l'electrovanne.

L'installation doit être entreprise en suivant les directives de IEC 79-14 et toute autre directive en application dans les codes nationaux.

Cette unité peut être utilisée en zones dangereuses jusqu'à Zone 1 inclus et est disponible en différents voltages et classifications "T". Veuillez vous référer au catalogue des produits RGS pour détails supplémentaires.

Protection contre atmosphères dangereuses ou autres dangers

Le corps d'electrovanne est fabriqué en acier inoxydable revêtu de peinture époxy-poudre.

Cette electrovanne ne doit pas être installée dans un environnement qui pourrait endommager cette apparence et causer une explosion ou affecter le niveau de protection.

Cette electrovanne a été conçue et fabriquée pour la protection contre d'autres dangers définis dans le paragraphe 1.2.7 / Annexe II de la directive ATEX 549/EC.

Éviter le contact de cet appareillage avec toute substance corrosive ou agressive.

Reparations / Remises en état

Cette electrovanne n'est pas destinée pour être réparée ou remise à neuf sur site. Dans le cas où cette pièce aurait besoin d'être réparée, elle doit être renvoyée à RGS.

Noter que des kits de réparations sont disponibles pour la plupart des manières des vannes pneumatiques sur lesquelles cette electrovanne peut être fixée. L'assemblage complet (qui inclut la base sur laquelle cette electrovanne est montée) peut être démonté/remonté sans affecter l'intégrité de cette electrovanne.

Location

Cette electrovanne et ses pièces de montage sont capables de supporter son propre poids et celui de la vanne pneumatique. Il faut faire attention à ne pas exposer le montage à un poids ou stress mécanique supplémentaires.

Cette electrovanne peut être montée dans n'importe quelle direction.

"T" Class	Max. Surface Temp.
3	200°C
4	133°C
5	100°C
6	85°C

R.G.S. Electro - Pneumatics Ltd.,
West End Business Park, Blackburn Road
Oswaldtwistle, Lancs., BB5 4WZ, England.

Tel. +44 (0)1254 872277
Fax. +44 (0)1254 390133
e-mail : sales@rgs-e-p.co.uk



Installation and Maintenance - Ex II 2 GD (EExd IIC T3-6) Solenoid
 Installazione e Manutenzione - Ex II 2 GD (EExd IIC T3-6) Elettrovalvola

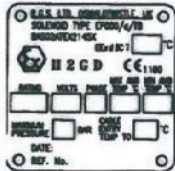
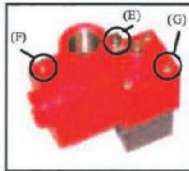
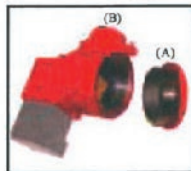

(GB)

Installation

The installation of this solenoid should only be undertaken by competent personnel.

- 1) Remove the M30 termination cover (A).
- 2) The electrical supply should be fed through the conduit entry (B).
- 3) Connect electrical supply leads to 2 pole terminal block (C). Note that these terminations may be marked as polarity sensitive, depending on the version supplied. Ensure that correct polarity is connected where marked as the solenoid may be damaged if polarity is reversed.
- 4) Make earth connections to internal earth point (D) or external earth point (E) as required.
- 5) On completion of electrical connections, refit the M30 termination cover (A), tighten and secure with locking screw (F).

• **Important Note.** Both threecore connections to the housing are flame paths and are an integral part of the Ex II 2 G enclosure. Ensure that both are securely tightened before the solenoid is energised.

• Installation should be undertaken in accordance with the requirements of IEC 79-14 and any relevant additional National codes of practice.

• When used in a dust atmosphere the flameproof entries or stopping plugs shall be selected and installed so that the dust tight (IP5X) integrity of the enclosure is maintained.

• If pozi-drive screws (G) are used a minimum of 1 screw is to be made tamperproof by deformation or application of a locking resin to fill the head recess.

• This unit is suitable for use in hazardous areas up to and including Cat. 2 and is available in various voltages and "T" Class ratings. Please refer to the RGS Product catalogue for details.

Protection from Hazardous Atmospheres and Other Hazards

• Solenoid enclosure manufactured from epoxy powder paint coated stainless steel.

• This solenoid must not be installed in environments that would react with the apparatus to cause explosions or affect the protection concept.

• This equipment is designed and manufactured to protect against other hazards as defined in paragraph 1.2.7 of Annex II of ATEX Directive 94/9/EC.

• Avoid exposing the equipment to aggressive substances.

Repair / Overhaul

• The solenoid is not designed to be repaired or overhauled in the field. In the event that the unit requires repair it must be returned to RGS.

• Note that repair kits are available for most pneumatic spool valves to which the solenoid valve is attached. The complete solenoid assembly may be removed / refitted to the spool valve without affecting the integrity of the solenoid.

Location

• The solenoid and its mountings are designed to support the self weight of the solenoid assembly. Care should be taken to avoid the unit being exposed to any further loads or mechanical stresses.

• The solenoid is designed to be installed in any orientation.



(I)

Installazione

L'installazione della elettrovalvola deve essere eseguita da personale competente.

- 1) Rimuovere il coperchio (A)
- 2) Inserire il cavo nel condotto (B)
- 3) Collegare i terminali di tensione al morsetto (C), in alcuni casi i terminali identificano le polarità, pertanto ove previsto rispettare le polarità durante la connessione elettrica.
- 4) Collegare il cavo di terra al morsetto (D) oppure al morsetto esterno (E)
- 5) Richiudere il box avvitando il coperchio (A) bloccando per sicurezza la vite (F)

Entrambe le connessioni filettate della custodia o box sono parti integrali della certificazione Ex II 2 G, ed assicurano una perfetta tenuta stagna verso l'esterno.

L'installazione deve essere eseguita in accordo alle Norme IEC 79-14, ed anche alle eventuali Norme previste ed in essere nel Paese dove avviene l'installazione.

Se utilizzato in atmosfera con presenza di polveri il pressacavo o il giunto di bloccaggio deve essere selezionato e installato in modo da mantenere il grado di protezione (IP5X) della custodia.

Se vengono utilizzate viti con testa ad incasso, almeno una vite deve essere del tipo antianomissione ottenuta deformando la stessa o applicando resine sigillanti che riempia il recesso della vite stessa.

Questa custodia o Box è adatta per l'impiego in aree pericolose inclusa la Cat. 2, e' disponibile in tutte le tensioni e bifrequenza; l'avvolgimento e' in classe T. Per ulteriori informazioni consultare il catalogo RGS.

Protezione in Ambienti Aggressivi O Con Pericolo Di Esplosione

La custodia o box e' costruita in AISI 304 con verniciatura epossidica.

Il solenoide non deve essere installato in ambienti c/o luoghi che possono disturbare altri apparati tecnici ed essere fonte di esplosioni o danni di qualsiasi altro genere o natura.

Il componente e' stato progettato e realizzato per impieghi in zone con pericolo di esplosione definite nel paragrafo 1.2.7 ANNEX II della direttiva ATEX 94/9/EC.

Evitare esplosioni dei componenti ad agenti aggressivi.

Revisione / Riparazione

Il solenoide non e' stato progettato per la sostituzione o riparazione in campo.

In caso di difetti o malfunzionamenti lo stesso deve essere reso a RGS.

Sono invece disponibili Kit di ricambio per ogni tipo di valvola pneumatica abbinata al solenoide.

Il solenoide può essere rimosso sostituito da uno nuovo senza causare problemi di funzionamento alcuno alla valvola pneumatica.

Montaggio

Il solenoide e' stato progettato e costruito per il montaggio in qualsiasi posizione.

Tutti i componenti che costituiscono il solenoide sono stati progettati e realizzati per garantire la corretta funzionalità dello stesso.

"T" Class	Max. Surface Temp.
3	200°C
4	133°C
5	100°C
6	85°C

8 Malfunctions

Depending on the operating conditions, check the valve at certain intervals to prevent a possible failure before it can occur. Plant operators are responsible for drawing up an inspection and test plan.

Malfunction	Possible reasons	Recommended action
The solenoid valve does not switch.	Turnable gasket incorrectly positioned.	Turn the turnable gasket as described in 6.3 or supply port 9 with air.
The solenoid valve leaks to the atmosphere.	O-rings slipped (NAMUR interface).	Check that the O-rings are correctly seated.
	Pilot pressure is insufficient and an intermediate position is reached (air is constantly vented)	Check the pressure line for leakage. Use a larger cross-section for the pressure line, if necessary.



EU Type Examination Certificate CML 15ATEX119X Issue 3

- 1 Equipment intended for use in Potentially Explosive Atmospheres Directive 2014/34/EU
- 2 Equipment **Type EP000/d/TB Solenoid Assembly**
- 3 Manufacturer **Pneumatrol Limited**
- 4 Address **West End Business Park,
Blackburn road,
Oswaldtwistle, Lancashire
BB5 4WZ, UK**
- 5 The equipment is specified in the description of this certificate and the documents to which it refers.
- 6 CML B.V. , Chamber of Commerce No 6738671, Hoogoorddreef 15, Amsterdam, 1101 BA, The Netherlands, Notified Body Number 2776, in accordance with Article 17 of Directive 2014/34/EU of the European Parliament and of the Council, dated 26 February 2014, certifies that this equipment has been found to comply with the Essential Health and Safety Requirements relating to the design and construction of equipment intended for use in potentially explosive atmospheres given in Annex II to the Directive.

The examination and test results are recorded in the confidential reports listed in Section 12.
- 7 If an 'X' suffix appears after the certificate number, it indicates that the equipment is subject to conditions of safe use (affecting correct installation or safe use). These are specified in Section 14.
- 8 This EU Type Examination certificate relates only to the design and construction of the specified equipment or component. Further requirements of Directive 2014/34/EU Article 13 apply to the manufacture of the equipment or component and are separately certified.
- 9 Compliance with the Essential Health and Safety Requirements, with the exception of those listed in the confidential report, has been demonstrated through compliance with the following documents:

EN 60079-0:2012+A11:2013 EN 60079-1:2014 EN 60079-31:2014
- 10 The equipment shall be marked with the following:

 II 2 G D

Ex db IIC T* Gb

Ex tb IIIC T* Gb

Ta = -65°C to +*°C

* For temperature class, assigned maximum surface temperature and maximum ambient, refer to Description.



CML 15ATEX1119X
Issue 3

11 Description

A Type EP000/d/TB Solenoid Assembly comprises a cast housing with an integral terminal enclosure and a threaded cover; all manufactured from grade ANC1B stainless steel to BS3146. The enclosure contains a coil rated at up to 3.2 W dc or 9.5 VA ac which is retained by a threaded end cap. The cap also positions and retains a centre tube which locates the pole piece and armature. Alternative coils may be fitted for 12 V to 440 V ac 50/60 Hz, or 6 V to 240 V dc supplies.

A two, or three-way terminal block is fitted within the terminal compartment. A bridge rectifier may also be fitted so that the 3 W dc coil can be operated from an appropriate ac or dc supply.

Internal and external earthing facilities are provided.

The temperature classifications, assigned maximum surface temperatures and ambient temperature range for each coil type are listed below:

Supply	Coil Rating (max)	Marking	Cable temperature
dc	3 W	Ex db IIC T6 Gb Ex tb IIIC T85°C Db (T _{amb} = -65°C to +40°C)	-
dc	3 W	Ex db IIC T5 Gb Ex tb IIIC T100°C Db (T _{amb} = -65°C to +55°C)	-
dc	3 W	Ex db IIC T4 Gb Ex tb IIIC T135°C Db (T _{amb} = -65°C to +60°C)	85°C
dc	3 W	Ex db IIC T4 Gb Ex tb IIIC T135°C Db (T _{amb} = -65°C to +80°C)	105°C
ac/dc (rectified)	3 W	Ex db IIC T5 Gb Ex tb IIIC T100°C Db (T _{amb} = -65°C to +55°C)	-
ac/dc (rectified)	3 W	Ex db IIC T6 Gb Ex tb IIIC T85°C Db (T _{amb} = -65°C to +40°C)	-
ac	9.5 VA	Ex db IIC T4 Gb Ex tb IIIC T135°C Db (T _{amb} = -65°C to +40°C)	90°C
ac	9.5 VA	Ex db IIC T3 Gb Ex tb IIIC T200°C Db (T _{amb} = -65°C to +55°C)	105°C

Cable entry holes are provided as specified on the approved drawings for the accommodation of



The cable entry devices, thread adapters and stopping plugs shall be suitable for the equipment, the cable and the conditions of use and shall be certified as Equipment (not a Component) under the EC/EU Type Examination Certificate to the ATEX Directive.

When used in dust atmospheres, the flameproof cable entries or stopping plugs shall be selected and installed so that the dust tight (IP66) integrity of the enclosure is maintained.

The equipment may alternatively be supplied with an integral cable and gland.

Variation 1

This variation introduces the following modifications:

- i. To allow an increase of the maximum ambient temperature of one of the models listed in the table in the Description from +60°C to +80°C. The Description has been updated accordingly.
- ii. To update the certificate references to the 2014/34/EU ATEX Directive
- iii. Minor drawing modifications

Variation 2

This variation introduces the following modifications:

- i. To update the marking to include additional information.

Variation 3

This variation introduces the following modifications:

- i. To allow the option of partially encapsulating the rectifier assembly within the flameproof enclosure.
- ii. To allow the option of supplying the equipment with a cable gland and cable attached, and fully encapsulating the terminal chamber.
- iii. To transfer the ATEX certificate to CML BV.

12 Certificate history and evaluation reports

Issue	Date	Associated report	Notes
0	21 Jan 2016	R715A/00	Issue of Prime Certificate
1	07 Oct 2016	R1574A/00	Introduction of Variation 1
2	03 Oct 2017	R11343A/00	Introduction of Variation 2
3	25 Jan 2019	R11628A/00	Introduction of Variation 3

Note: Drawings that describe the equipment or component are listed in the Annex.



CML 15ATEX1119X
Issue 3

13 Conditions of Manufacture

The following conditions are required of the manufacturing process for compliance with the certification.

- i. The inside of the centre tube assembly shall be subjected to a routine test of 1.5 times the defined/marked maximum working pressure. It shall be shown that the flameproof enclosure cannot become pressurised as a result of leakage of the pressurised medium from the centre tube assembly. The end-user shall be informed of the maximum working pressure of the centre tube assembly.
- ii. If supplied with integral cable and cable gland, the manufacturer shall ensure that the cable meets all the applicable requirements of EN60079-14 and that the cable gland is certified to EN60079-0 and EN60079-1 and provides a minimum degree of protection of IP6X. The cable gland and cable shall be suitable for an operating temperature as defined on Table A of drawing CV5358 sheet 3.

14 Specific Conditions of Use (Special Conditions)

The following conditions relate to safe installation and/or use of the equipment.

- i. The dimensions of the flamepaths shall not be modified. In the event that the unit requires repair, it must be returned to the manufacturer.
- ii. The non-metallic paint/coating on the enclosure is considered to be a potential electrostatic charging hazard. The equipment shall be cleaned only with a damp cloth.



Certificate Annex

Certificate Number CML 15ATEX1119X
Equipment Type EP000/d/TB Solenoid Assembly
Manufacturer Pneumatrol Limited

The following documents describe the equipment or component defined in this certificate:

Issue 0

Drawing No	Sheets	Rev	Approved date	Title
CV5358	1 of 1	4	21 Jan 2016	Ex d Terminals Box Coil Assembly for IIC Gas Group
AV5359	1 of 1	4	21 Jan 2016	Label for EP000/EXD/ATEX for IIC Gas Group

Issue 1

Drawing No	Sheets	Rev	Approved date	Title
CV5358	1 of 1	5	07 Oct 2016	Ex d Terminal Box Coil Assembly for IIC Gas Group.
AV5359	1 of 1	5	07 Oct 2016	Label for EP000/EXD/ATEX For IIC Gas Group

Issue 2

Drawing No	Sheets	Rev	Approved date	Title
CV5358*	1 of 1	5	03 Oct 2017	Ex d Terminal Box Coil Assembly for IIC Gas Group.
AV5359	1 of 1	6	03 Oct 2017	Label for EP000/EXD/ATEX For IIC Gas Group

*Note: This drawing has not been updated and has been included for completeness only.



Certificate Annex

Certificate Number CML 15ATEX1119X
Equipment Type EP000/d/TB Solenoid Assembly
Manufacturer Pneumatrol Limited

Issue 3

Drawing No	Sheets	Rev	Approved date	Title
AV5359	1 of 1	7	25 Jan 2019	Label for EP000/EXD/ATEX for IIC Gas Group
CV5358	1 of 3	5	25 Jan 2019	Ex d Terminal box coil assembly for IIC gas group
CV5358	2 of 3	5	25 Jan 2019	Ex d Terminal box coil assembly for IIC gas group
CV5358	3 of 3	5	25 Jan 2019	Ex d Terminal box coil assembly for IIC gas group
V6324-E5-00	1 of 1	-	25 Jan 2019	Bridge rectifier terminal board



EU Konformitätserklärung / EU Declaration of Conformity

Für das folgende Produkt / For the following product

Vorsteuerventil / E/P Binary Converter Typ / Type 3962

- wird die Konformität mit den nachfolgenden EU-Richtlinien bestätigt / signifies compliance with the following EU Directives:

- | | |
|-------------------------------------|---------------------------------------|
| EMC 2004/108/EC (bis/to 2016-04-19) | EN 61000-6-2:2005, EN 61000-6-3:2010, |
| EMC 2014/30/EU (ab/from 2016-04-20) | EN 61326-1:2006 |
| LVD 2006/95/EC (bis/to 2016-04-19) | EN 61010-1:2010 |
| LVD 2014/35/EU (ab/from 2016-04-20) | |

Hersteller / Manufacturer:

SAMSON AKTIENGESELLSCHAFT
Weismüllerstraße 3
D-60314 Frankfurt am Main
Deutschland/Germany

Frankfurt, 2016-04-06

eu_3962-0_de_en_rev05.pdf

Gert Nahler
Zentralabteilungsleiter/Head of Department
Entwicklung Automation und Integrationstechnologien/
Development Automation and Integration Technologies

ppa. Günther Scherer
Qualitätssicherung/Quality Management

EB 3962-9 EN



SAMSON AKTIENGESELLSCHAFT
Weismüllerstraße 3 · 60314 Frankfurt am Main, Germany
Phone: +49 69 4009-0 · Fax: +49 69 4009-1507
samson@samsongroup.com · www.samsongroup.com