

MOUNTING AND OPERATING INSTRUCTIONS

The SAMSON logo consists of the word "SAMSON" in a bold, white, sans-serif font, centered within a solid black circle. This circle is itself centered within a white square frame.

EB 3003 EN

Translation of original instructions



Type 42-24 Differential
Pressure Regulator



Type 42-28 Differential
Pressure Regulator

Type 42-24 and Type 42-28 Differential Pressure Regulators

Self-operated Regulators · Closing Actuator

Note on these mounting and operating instructions

These mounting and operating instructions assist you in mounting and operating the device safely. The instructions are binding for handling SAMSON devices. The images shown in these instructions are for illustration purposes only. The actual product may vary.

- For the safe and proper use of these instructions, read them carefully and keep them for later reference.
- If you have any questions about these instructions, contact SAMSON's After-sales Service (aftersalesservice@samsongroup.com).



The mounting and operating instructions for the devices are included in the scope of delivery. The latest documentation is available on our website at www.samsongroup.com > **Downloads** > **Documentation**.

Definition of signal words

DANGER

Hazardous situations which, if not avoided, will result in death or serious injury

WARNING

Hazardous situations which, if not avoided, could result in death or serious injury

NOTICE

Property damage message or malfunction

Note

Additional information

Tip

Recommended action

1	Safety instructions and measures	1-1
1.1	Notes on possible severe personal injury	1-4
1.2	Notes on possible personal injury	1-5
1.3	Notes on possible property damage	1-7
2	Markings on the device	2-1
2.1	Nameplates	2-1
2.2	Location of the nameplates	2-2
2.3	Material identification number	2-2
2.3.1	Type 2422 Valve	2-2
2.3.2	Type 2424 and Type 2428 Actuators	2-2
3	Design and principle of operation	3-1
3.1	Additional fittings	3-4
3.2	Technical data	3-5
4	Shipment and on-site transport	4-1
4.1	Accepting the delivered goods	4-1
4.2	Removing the packaging from the regulator	4-1
4.3	Transporting and lifting the regulator	4-2
4.3.1	Transporting the regulator	4-2
4.3.2	Lifting the regulator	4-3
4.4	Storing the regulator	4-4
5	Installation	5-1
5.1	Installation conditions	5-1
5.2	Preparation for installation	5-4
5.2.1	Cleaning the pipeline	5-4
5.3	Installation	5-6
5.3.1	Installing the regulator	5-7
5.3.2	Filling the plant	5-8
5.4	Testing the regulator	5-8
5.4.1	Leakage	5-9
5.4.2	Pressure test	5-10
5.5	Insulation	5-11
6	Start-up	6-1
6.1	Start-up and putting the device back into operation	6-1
6.2	Starting up the plant	6-2
7	Operation	7-1
7.1	Adjusting the differential pressure set point	7-1

Contents

8	Malfunctions	8-1
8.1	Troubleshooting	8-1
8.2	Emergency action	8-3
9	Servicing.....	9-1
9.1	Preparing the valve for service work	9-6
9.2	Installing the regulator after service work	9-6
9.3	Service work.....	9-6
9.4	Replacing the actuator	9-6
9.5	Replacing the seat and plug.....	9-7
9.6	Exchanging the operating diaphragm unit in the actuator	9-7
9.6.1	Type 2428 Actuator	9-7
9.6.2	Type 2424 Actuator	9-7
9.7	Ordering spare parts and operating supplies	9-8
10	Decommissioning	10-1
11	Removal	11-1
11.1	Removing the regulator from the pipeline	11-1
11.2	Removing the actuator from the valve	11-1
12	Repairs	12-1
12.1	Returning devices to SAMSON	12-1
13	Disposal.....	13-1
14	Certificates.....	14-1
15	Appendix.....	15-1
15.1	Tightening torques.....	15-1
15.2	Lubricants.....	15-1
15.3	Tools	15-1
15.1	Accessories	15-1
15.4	Spare parts	15-2
15.5	After-sales service	15-7

1 Safety instructions and measures

Intended use

The SAMSON Type 42-24 and Type 42-28 Regulators are differential pressure regulators. They consist of a Type 2422 Valve and a Type 2424 Actuator (Type 42-24) or a Type 2428 Actuator (Type 42-28). These regulator components are delivered separately.

The self-operated regulators are used to control the differential pressure in plants. Liquids, gases and vapors in district heating system, extended heating systems or industrial plants can be controlled by the regulators.

The regulators are designed to operate under exactly defined conditions (e.g. operating pressure, process medium, temperature). Therefore, operators must ensure that the regulators are only used in operating conditions that meet the specifications used for sizing the devices at the ordering stage. In case operators intend to use the regulators in applications or conditions other than those specified, contact SAMSON.

SAMSON does not assume any liability for damage resulting from the failure to use the device for its intended purpose or for damage caused by external forces or any other external factors.

➔ Refer to the technical data and nameplate for limits and fields of application as well as possible uses.

Reasonably foreseeable misuse

The regulators are not suitable for the following applications:

- Use outside the limits defined during sizing and by the technical data
- Use outside the limits defined by the additional fittings mounted on the regulator

Furthermore, the following activities do not comply with the intended use:

- Use of non-original spare parts
- Performing service and repair work not described

Qualifications of operating personnel

The regulator must be mounted, started up, serviced and repaired by fully trained and qualified personnel only; the accepted industry codes and practices must be observed. According to these mounting and operating instructions, trained personnel refers to individuals who are able to judge the work they are assigned to and recognize possible hazards due to their specialized training, their knowledge and experience as well as their knowledge of the applicable standards.

Safety instructions and measures

Personal protective equipment

We recommend checking the hazards posed by the process medium being used (e.g.

▶ GESTIS (CLP) hazardous substances database). Depending on the process medium and/or the activity, the protective equipment required includes:

- Protective clothing, safety gloves and eye protection in applications with hot, cold and/or corrosive media
 - Wear hearing protection when working near the valve. Follow the instructions given by the plant operator.
 - Hard hat
 - Safety harness when working at height
 - Safety footwear, ESD (electrostatic discharge) footwear, if necessary
- ➔ Check with the plant operator for details on further protective equipment.

Revisions and other modifications

Revisions, conversions or other modifications of the product are not authorized by SAMSON. They are performed at the user's own risk and may lead to safety hazards, for example. Furthermore, the product may no longer meet the requirements for its intended use.

Warning against residual hazards

To avoid personal injury or property damage, plant operators and operating personnel must prevent hazards that could be caused in the regulator by the process medium, the operating pressure or by moving parts by taking appropriate precautions. Plant operators and operating personnel must observe all hazard statements, warning and caution notes in these mounting and operating instructions.

Hazards resulting from the special working conditions at the installation site of the regulator must be identified in a risk assessment and prevented through the corresponding safety instructions drawn up by the operator.

We also recommend checking the hazards posed by the process medium being used (e.g.

▶ GESTIS (CLP) hazardous substances database).

- ➔ Observe safety measures for handling the device as well as fire prevention and explosion protection measures.

These mounting and operating instructions deals with the standard version of the device. Components of the device that differ to those used for the standard version described in this document can be exchanged with other certain SAMSON components. The residual hazards of these components are described in the associated mounting and operating instructions (see documents listed under 'Referenced documentation').

Safety features

The Types 42-24 and 42-28 Regulators do not have any special safety features. When relieved of pressure, the regulators are opened by the force of the set point springs.

Responsibilities of the operator

Operators are responsible for proper use and compliance with the safety regulations. Operators are obliged to provide these mounting and operating instructions as well as the referenced documents to the operating personnel and to instruct them in proper operation. Furthermore, operators must ensure that operating personnel or third parties are not exposed to any danger.

Operators are additionally responsible for ensuring that the limits for the product defined in the technical data are observed. This also applies to the start-up and shutdown procedures. Start-up and shutdown procedures fall within the scope of the operator's duties and, as such, are not part of these mounting and operating instructions. SAMSON is unable to make any statements about these procedures since the operative details (e.g. differential pressures and temperatures) vary in each individual case and are only known to the operator.

Responsibilities of operating personnel

Operating personnel must read and understand these mounting and operating instructions as well as the referenced documents and observe the specified hazard statements, warnings and caution notes. Furthermore, operating personnel must be familiar with the applicable health, safety and accident prevention regulations and comply with them.

Referenced standards, directives and regulations

The regulators comply with the requirements of the Pressure Equipment Directive 2014/68/EU and the European Machinery Directive 2006/42/EC. Regulators with a CE marking have a declaration of conformity, which includes information about the applied conformity assessment procedure. The corresponding declaration of conformity is included in the 'Certificates' chapter.

According to the ignition risk assessment performed in accordance with Clause 5.2 of ISO 80079-36, the non-electrical regulators do not have their own potential ignition source even in the rare incident of an operating fault. As a result, they do not fall within the scope of Directive 2014/34/EU.

→ For connection to the equipotential bonding system, observe the requirements specified in Clause 6.4 of EN 60079-14 (VDE 0165-1).

Safety instructions and measures

Referenced documentation

The following documents apply in addition to these mounting and operating instructions:

- Mounting and operating instructions for
e.g. **Type 2 N or NI Strainer** ▶ EB 1015
- Data sheets for
e.g. **Accessories · Differential pressure and flow regulators** ▶ T 3095

- e.g. **Type 2 N or NI Strainer** ▶ T 1015
- Mounting and operating instructions as well as data sheets for additional fittings (e.g. shut-off valves, pressure gauges etc.).

1.1 Notes on possible severe personal injury

DANGER

Risk of bursting in pressure equipment.

Regulators and pipelines are pressure equipment. Impermissible pressure or improper opening can lead to regulator components bursting.

- Observe the maximum permissible pressure for regulator and plant.
- If necessary, a suitable overpressure protection must be installed on site in the plant section.
- Before starting any work on the regulator, depressurize all plant sections affected as well as the regulator.
- Drain the process medium from all the plant sections affected as well as the regulator.
- Wear personal protective equipment.

1.2 Notes on possible personal injury

WARNING

Risk of personal injury through incorrect operation, use or installation as a result of information on the regulator being illegible.

Over time, markings, labels and nameplates on the regulator may become covered with dirt or become illegible in some other way. As a result, hazards may go unnoticed and the necessary instructions not followed. There is a risk of personal injury.

- Keep all relevant markings and inscriptions on the device in a constantly legible state.
- Immediately renew damaged, missing or incorrect nameplates or labels.

Risk of hearing loss or deafness due to loud noise.

The noise emissions depend on the valve version, plant facilities and process medium.

- Wear hearing protection when working near the valve. Follow the instructions given by the plant operator.

Crush hazard arising from moving parts.

The regulator contains moving parts (set point springs), which can injure hands or fingers if inserted into the regulator.

- Do not insert hands or fingers between the set point springs while the regulator is in operation.
- Before performing any work on the regulator, depressurize the plant. Disconnect or shut off the control line.

Risk of personal injury due to loaded springs.

The set point springs of regulators with adjusted set point are preloaded and are under tension.

- Before starting any work on the springs, relieve the compression from the preloaded springs.

WARNING

Risk of personal injury due to pressurized components and process medium being discharged.

Incorrect opening of pressure equipment or mounting parts may lead to the process medium escaping to the atmosphere.

- Do not loosen the control line while the valve is pressurized.
- Do not start up the regulator until all parts have been mounted.

Risk of burn injuries due to hot or cold components and pipelines.

Depending on the process medium, regulator components and pipelines may get very hot or cold and cause burn injuries.

- Allow components and pipelines to cool down or warm up to the ambient temperature.
- Wear protective clothing and safety gloves.

Damage to health relating to the REACH regulation.

If a SAMSON device contains a substance which is listed as being a substance of very high concern on the candidate list of the REACH regulation, this circumstance is indicated on the SAMSON delivery note.

- Information on safe use of the part affected ► www.samsongroup.com/en/about-samson/material-compliance/reach-regulation/.

Risk of personal injury due to residual process medium in the regulator.

While working on the regulator, residual process medium can escape and, depending on its properties, may lead to personal injury, e.g. (chemical) burns.

- If possible, drain the process medium from all the plant sections affected and the regulator.
- Wear protective clothing, safety gloves and eye protection.

1.3 Notes on possible property damage

! NOTICE

Risk of regulator damage due to incorrectly attached slings.

- Do not attach load-bearing slings to the actuator housing (see information under 'Lifting the regulator' in the 'Shipment and on-site transport' chapter).

Risk of regulator damage due to unsuitable medium properties.

The regulator is designed for a process medium with defined properties.

- Only use the process medium specified for sizing the equipment.

Risk of regulator damage due to contamination (e.g. solid particles) in the pipeline.

The plant operator is responsible for cleaning the pipelines in the plant.

- Flush the pipelines before start-up.

Risk of regulator damage due to the use of unsuitable lubricants.

The lubricants to be used depend on the regulator material. Unsuitable lubricants may corrode and damage surfaces.

- Only use lubricants approved by SAMSON.
When in doubt, consult SAMSON.

Risk of leakage and regulator damage due to excessively high or low tightening torques.

Observe the specified torques when tightening regulator components. Excessive tightening torques lead to parts wearing out more quickly. Parts that are too loose may cause leakage.

- Observe the specified tightening torques (see 'Tightening torques' in the Appendix).

Risk of regulator damage due to the use of unsuitable tools.

Certain tools are required to work on the regulator.

- Only use tools approved by SAMSON.
When in doubt, consult SAMSON.

! NOTICE

Risk of the process medium being contaminated through the use of unsuitable lubricants and/or contaminated tools and components.

- Keep the regulator and the tools used free from solvents and grease.
- Make sure that only suitable lubricants are used.

Risk of excess pressure damaging plant sections due to construction-related seat leakage through the regulator.

- Always install a safety device (e.g. safety excess pressure valve or safety relief valve) in the plant.

Incorrect control due to the formation of ice on the regulator.

Medium temperatures below 0 °C may cause ice to form on the regulator, depending on the air humidity. This may affect, in particular, the functioning of the plug or diaphragm stem guide.

- Prevent the formation of ice by taking appropriate precautions (e.g. enclosure, trace heater etc.). The plant operator is responsible for selecting and implementing appropriate precautions. See the 'Installation' chapter.

i Note

SAMSON's After-sales Service can support you concerning lubricant, tightening torques and tools approved by SAMSON.

2 Markings on the device

Several nameplates are affixed to the device. The nameplates shown were up to date at the time of publication of this document. The nameplates on the device may differ from

the ones shown. The nameplates are used to identify the separate regulator components (see Chapter 2.1).

2.1 Nameplates

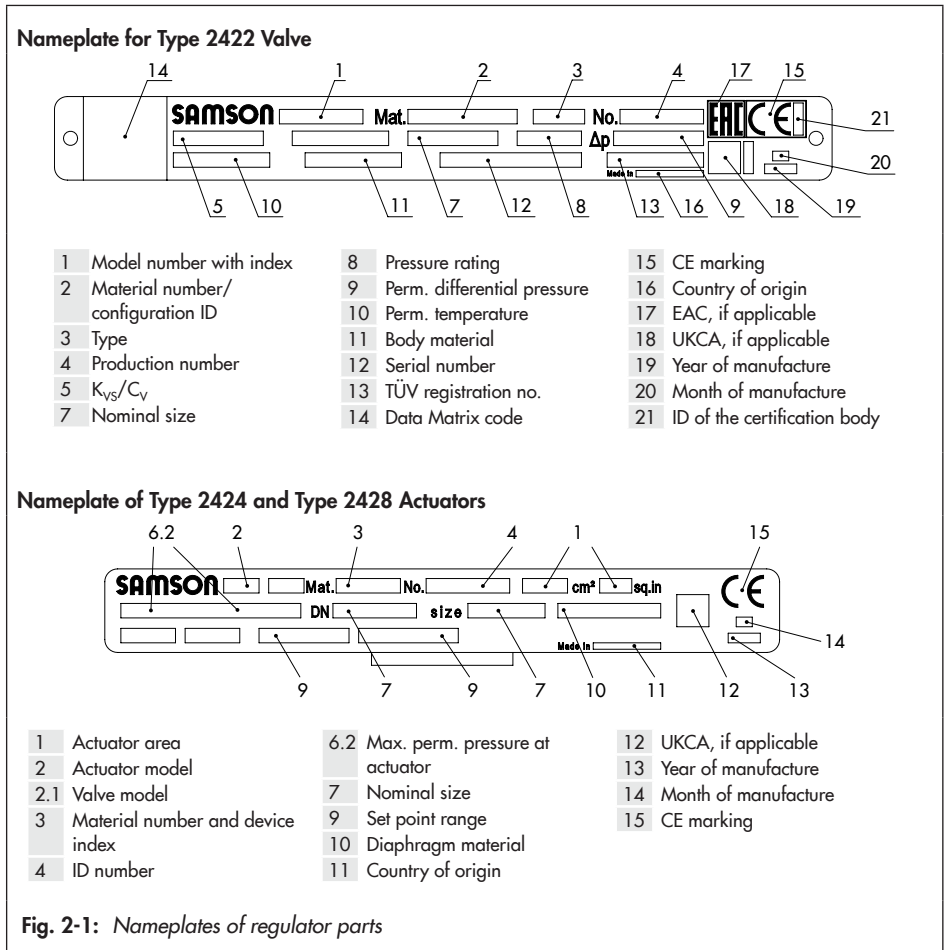
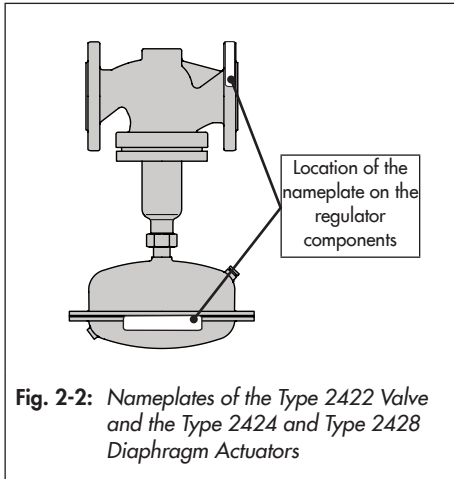

Fig. 2-1: Nameplates of regulator parts

2.2 Location of the nameplates



2.3 Material identification number

2.3.1 Type 2422 Valve

See the nameplate (11 for DIN/ANSI version, body material) for the material used. For more details on the nameplate, see Chapter 2.1.

2.3.2 Type 2424 and Type 2428 Actuators

Specifying the material number, you can contact us to find out which material is used. It is specified on the nameplate in the 'MNo.' field (3 for DIN/ANSI). For more details on the nameplate, see Chapter 2.1.

3 Design and principle of operation

→ See Fig. 3-1 and Fig. 3-2

The differential pressure regulators are designed to maintain the differential pressure between the high-pressure and low-pressure lines to a defined set point.

Type 42-24 · The set point can be adjusted as required within the set point range.

Type 42-28 · The set point is fixed.

The regulators basically consist of the Type 2422 Valve with seat (2) and plug (3) and a closing actuator (Type 2424 or Type 2428) with an operating diaphragm (13). Valve and actuator are delivered separately and must be assembled on site using a coupling nut (11).

The medium flows through the area released between the plug (3) and seat (2) in the direction indicated by the arrow. The position of the valve plug determines the differential pressure prevailing across the plant.

The standard Type 2422 Valve is pressure-balanced. The forces acting on the valve plug created by the upstream and downstream pressures are balanced by a balancing bellows (5) or balancing diaphragm ¹⁾ (5.1).

Regulators balanced by a bellows or a diaphragm only differ in the pressure balancing principle applied. Valves balanced by a diaphragm have a balancing diaphragm (5.1) instead of the balancing bellows (5). The downstream pressure p_2 acts on the bottom of the diaphragm and the upstream pressure p_1 on the top of the diaphragm. As a result, the forces created

by the upstream and downstream pressures acting on the plug are balanced out.

The differential pressure across the plant is transmitted over the high pressure and low pressure lines to the operating diaphragm (13) where it is converted into a positioning force. This force moves the plug according to the force of the set point springs (16).

The set point springs are mounted inside the actuator for a fixed set point (Type 42-28). The set point springs can be adjusted externally for an adjustable set point (Type 42-24).

Control lines (20) mounted on site transfer the high pressure and low pressure in all versions.

Type 2424 and Type 2428 Actuators are equipped with an overload protection (21). It prevents a rise in differential pressure during extreme operating conditions (e.g. vacuum at the heat exchanger) by opening an internal excess pressure limiter. As a result, plants and the regulator itself are protected against excessively high differential pressures.

The actuator with two diaphragms (special version) offers increased safety and reliability of functions. A bore with a mechanical diaphragm rupture indicator (34) is located in the intermediate ring located between the two operating diaphragms (31 and 32). The pressure of response of the diaphragm rupture indication is approximately 1.5 bar/22 psi.

¹⁾ Type 2422 Valve, balanced by a diaphragm, DN 65 to 250 only

Design and principle of operation

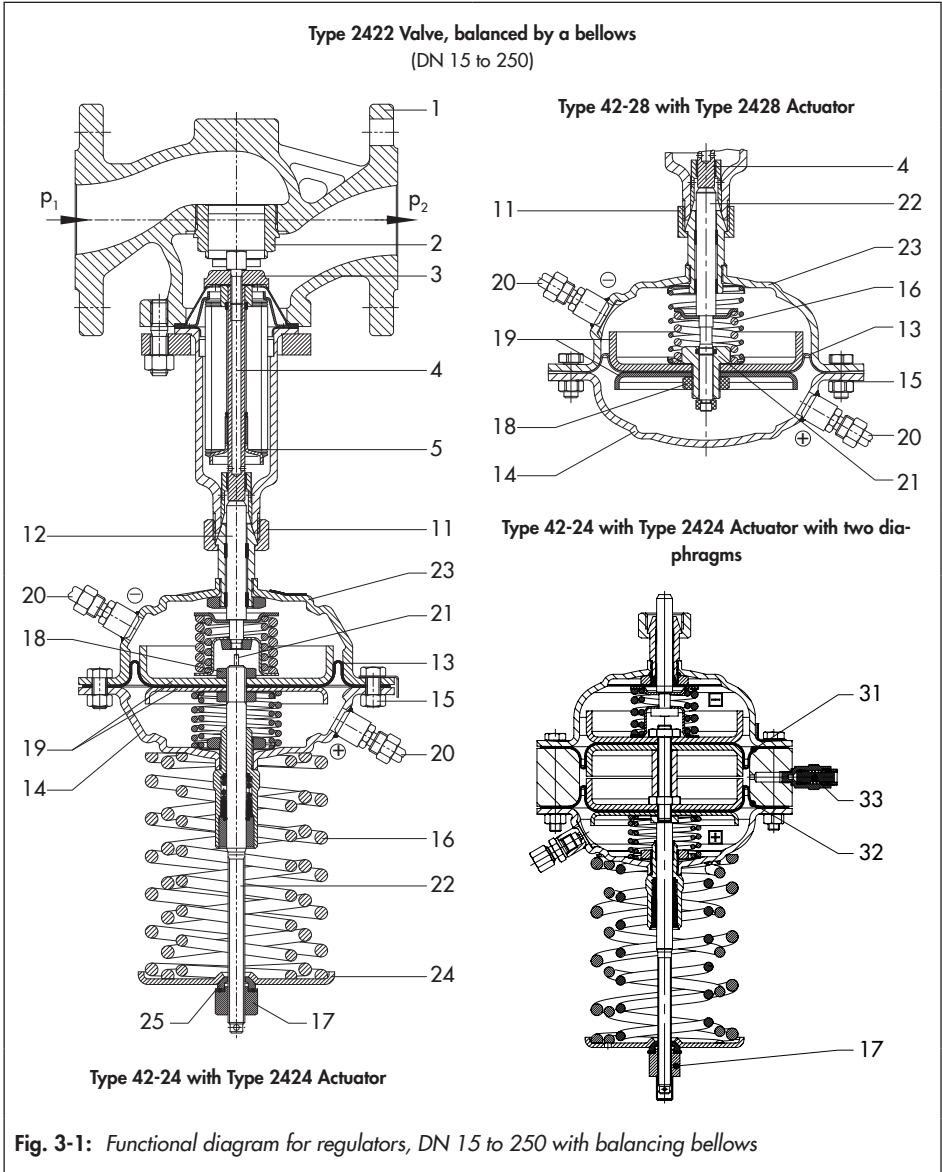

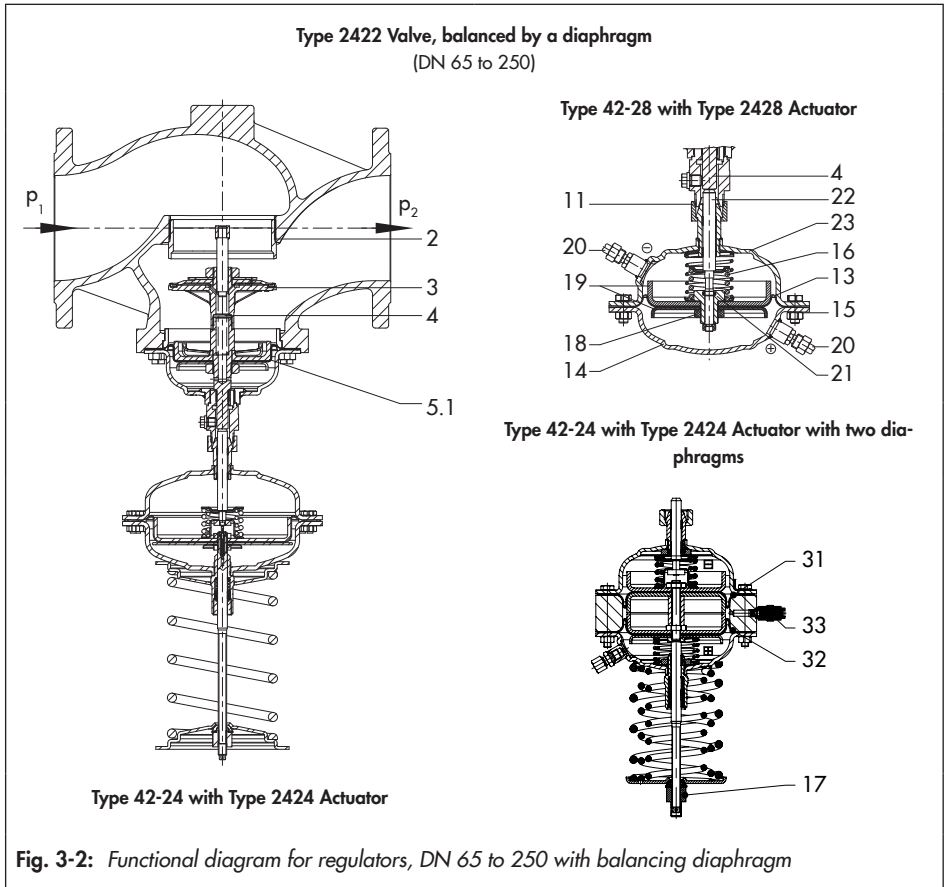

Legend for Fig. 3-1 and Fig. 3-2

1 Valve body	13 Operating diaphragm	21 Overload protection (force limiter with internal excess pressure limiter)	25 Axial needle bearing with washer
2 Seat	14 Bottom diaphragm case (valve on top)	22 Diaphragm stem	31 Operating diaphragm for high pressure
3 Plug	15 Nuts and bolts	23 Top diaphragm case (valve on top)	32 Operating diaphragm for low pressure
4 Plug stem	16 Set point springs	24 Spring plate	33 Diaphragm rupture indicator
5 Balancing bellows	17 Set point adjuster		
5.1 Balancing diaphragm (DN 65 to 250)	18 Nut		
11 Coupling nut	19 Diaphragm plate		
12 Diaphragm stem	20 Control line		

Design and principle of operation

In the event of a diaphragm rupture, the pressure in the space between the two operating diaphragms starts to increase. This causes the pin in the diaphragm rupture indicator to be pushed outwards and a red ring appears, indicating the diaphragm rupture. The intact operating diaphragm takes on the control task of the ruptured diaphragm.

A pressure switch (accessories) can be optionally mounted to the actuator to trigger an alarm.

3.1 Additional fittings

→ See Fig. 3-3

Pressure gauges

Install a pressure gauge (3 and 5) at suitable points to monitor the pressures prevailing in the plant.

Bypass and shut-off valves

We recommend installing a shut-off valve (1 and 6) both upstream of the strainer and downstream of the regulator and installing a bypass line. The bypass ensures that the plant does not need to be shut down for service and repair work on the regulator.

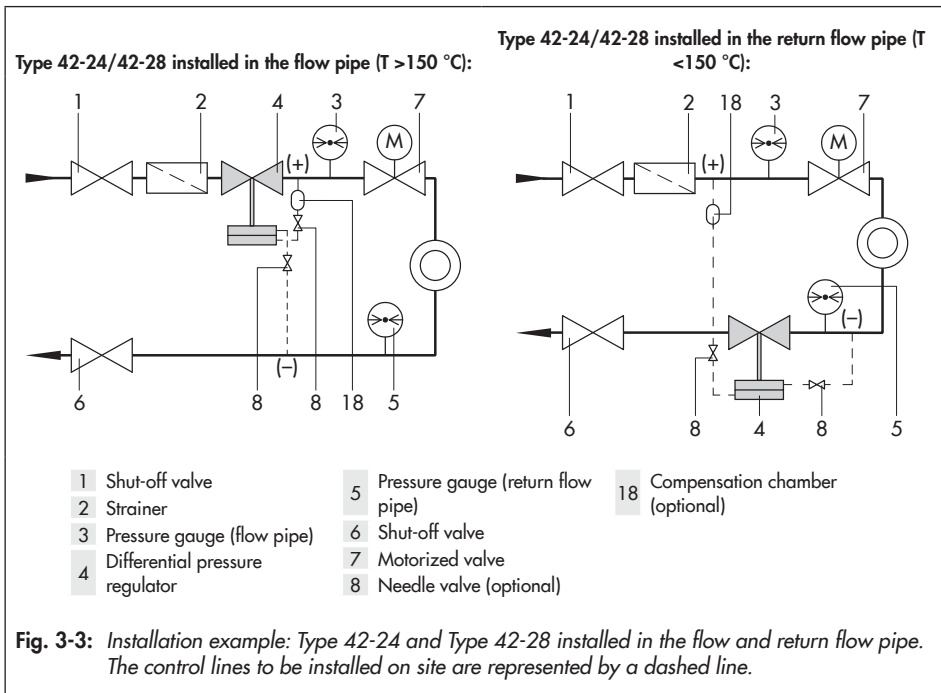

Strainers

We recommend installing a SAMSON strainer (2) upstream of the valve. It prevents solid particles in the process medium from damaging the regulator.

- ➔ Do not use the strainer to permanently filter the process medium.
- ➔ Select a strainer (mesh size) suitable for the process medium.

i Note

Any impurities carried along by the process medium may impair the proper functioning of the regulator. We recommend installing a strainer (e.g. SAMSON Type 2 NI) upstream of the pressure reducing valve (▶ EB 1015).

Insulation

Regulators can be insulated to reduce heat energy transfer.

Refer to the instructions in the 'Installation' chapter.

i Note

The Type 42-24 and Type 42-28 Regulators are not safety valves. If necessary, a suitable overpressure protection must be installed on site in the plant section.

3.2 Technical data

The valve and actuator nameplates provide information on the valve and actuator versions (see the 'Markings on the device' chapter).

i Note

More information is available in Data Sheet ▶ T 3003.

Conformity

The Type 42-24 and Type 42-28 Regulators bear the CE mark of conformity.



Process medium and scope of application

The differential pressure regulators are designed to maintain the differential pressure between the high-pressure and low-pressure lines to a defined set point.

- Suitable for **liquids and vapors**, max. temperature **350 °C/660 °F** ¹⁾
- Suitable for **gases**, max. temperature **80 °C/175 °F**
- Set points from **0.05 to 10 bar**
- Nominal size **DN 15 to 250**
- Pressure ratings from **PN 16 to 40**

The regulator is open when relieved of pressure. The valve **closes** when the differential pressure **rises**.

¹⁾ With compensation chamber and extension piece (optional)

Design and principle of operation

Leakage class

The metal-seated regulator has the leakage class I according to IEC 60534-4.

The soft-seated regulator has the leakage class IV according to IEC 60534-4.

Temperature range

Depending on how the regulator is configured, it can be used up to temperatures of 350 °C/660 °F (see Table 3-1). The minimum temperature is limited by the accessories used and the actuator's diaphragm material (► T 3003).

Noise emissions

SAMSON is unable to make general statements about noise emissions. The noise emissions depend on the regulator version, plant facilities, process medium and operating conditions.

Dimensions and weights

Table 3-4 to Table 3-6 provide an overview of the dimensions and weights. The lengths and heights in the dimensional drawings are shown on pages 3-11 and 3-12.

Table 3-1: Technical data · All pressures in bar (gauge)

Type	42-24				42-28	
Nominal size	DN 15 to 250				DN 15 to 100	
Pressure rating	PN 16, 25, 40					
Max. permissible temperature	Valve	See pressure-temperature diagram in ► T 3000				
	Actuator ¹⁾	With compensation chamber: steam and liquids up to 220 °C ²⁾ Without compensation chamber: liquids up to 150 °C · Air and gases up to 80 °C				
Set point ranges · Differential pressure across the restriction	0.05 to 0.25 bar · 0.1 to 0.6 bar · 0.2 to 1 bar · 0.5 to 1.5 bar · 1 to 2.5 bar · 2 to 5 bar · 4.5 to 10 bar ³⁾				0.2 bar, 0.3 bar, 0.4 bar or 0.5 bar	
Actuator area A	80 cm ²	160 cm ²	320 cm ²	640 cm ²	160 cm ²	320 cm ²
Pressure above adjusted set point at which internal excess pressure limiter responds	2.4 bar	1.2 bar	0.6 bar	0.3 bar	0.6 bar	0.3 bar
Max. permissible operating pressure	40 bar for 80 to 320 cm ² · 40 and 16 bar for 640 cm ²					
Max. perm. operating pressure for actuator with two diaphragms	40 bar		25 bar		–	
Conformity	CE · UK · EAC					
Leakage class acc. to IEC 60534-4	≤0.05 % of K _{V5} coefficient					

¹⁾ Max. 350 °C/660 °F with extension piece

²⁾ Steam version only with valves balanced by a bellows

³⁾ DN 125 to 250: 4.5 to 10 bar on request

Table 3-2: Materials · Material numbers according to DIN EN

Type 2422 Valve · Balanced by a bellows					
Nominal size	DN 15 to 250				
Pressure rating	PN 16	PN 16, 25	PN 16, 25, 40		
Valve body	Cast iron EN-GJL-250	Sph. graphite iron EN-GJS-400-18-LT	Cast steel 1.0619	Cast stainless steel 1.4408	Forged stainless steel 1.4404 ¹⁾
Seat	1.4401/1.4404 or 1.4006			1.4404	
Plug	Up to DN 100 ²⁾ Stainless steel 1.4401/1.4404 or 1.4006				
	DN 125 to 250 1.4404, with PTFE soft seal				
Plug stem	1.4301				
Metal bellows	DN 15 to 100: 1.4571 · DN 125 to 250: 1.4404				
Bottom section	P265GH			1.4571	
Body gasket	Graphite on metal core				
Type 2422 Valve · Balanced by a diaphragm					
Nominal size	DN 65 to 100				
Pressure rating	PN 16			PN 25	
Valve body	Cast iron EN-GJL-250			Spheroidal graphite iron EN-GJS-400-18-LT	
Seat	1.4408				
Plug	CW617N				
Diaphragm case	1.0619				
Pressure balancing	Diaphragm plate 1.4301 · EPDM balancing diaphragm, max. 150 °C				
Nominal size	DN 125 to 250				
Pressure rating	PN 16	PN 16 and 25	PN 16, 25, 40		
Valve body	Cast iron EN-GJL-250	Sph. graphite iron EN-GJS-400-18-LT	Cast steel 1.0619	Cast stainless steel 1.4408	
Seat	CC499K ³⁾				
Plug	CC499K ³⁾ · With EPDM or FKM soft seal, max. 150 °C				
Pressure balancing	Diaphragm plate EN-JS1030 · EPDM balancing diaphragm, max. 150 °C				
Type 2424 and Type 2428 Actuators					
Valve body	Cast iron, spheroidal graphite iron, cast steel 1.0619			Forged steel, cast stainless steel	
Diaphragm cases	1.0332			1.4301	
Diaphragm	EPDM ⁴⁾ with fabric reinforcement				
Guide bushing	DU bushing			PTFE	
Seals	EPDM/PTFE ⁴⁾				

¹⁾ DN 15, 25, 40 and 50 only

²⁾ Optionally with soft seal with standard K_{vs} coefficients

³⁾ Special version in 1.4409

⁴⁾ Special version, e.g. for mineral oils: FKM using an actuator with two diaphragms

Design and principle of operation

Table 3-3: K_{VS} coefficients, x_{FZ} values and max. permissible differential pressures Δp

Type 2422 Valve · Balanced by a bellows														
Nominal size DN	15	20	25	32	40	50	65	80	100	125	150	200	250	
Valve travel	10 mm						16 mm			22 mm				
K_{VS} coefficient	4.0	6.3	8.0	16	20	32	50	80	125	190	280	420	500	
Max. permissible differential pressure Δp	25 bar						20 bar			16 bar		12 bar	10 bar	
Reduced K_{VS} coefficient	-		4.0	6.3	8.0	16	32			80	80	125	280	
Max. permissible differential pressure Δp	25 bar						20 bar			16 bar		12 bar	10 bar	
x_{FZ} value	0.65	0.6	0.55		0.45		0.4		0.35				0.3	
Type 2422 Valve · Balanced by a diaphragm														
Nominal size DN	65		80		100		125		150		200		250	
Valve travel	15 mm						35 mm							
K_{VS} coefficient	50		80		125		250		390		650		800	
Max. permissible differential pressure Δp	12 bar				10 bar		12 bar				10 bar			
x_{FZ} value	0.4		0.35						0.3					
Type 2422 Valve · Unbalanced														
Nominal size DN	15		20		25		32		40		50			
Valve travel	10 mm													
K_{VS} coefficient	4.0		4.0 · 6.3		4.0 · 6.3 · 8.0		16		20		32			
Max. permissible differential pressure Δp	14 bar						6 bar				4 bar			
x_{FZ} value	0.65		0.6		0.55				0.45		0.4			
Reduced K_{VS} coefficient	0.1 · 0.4 · 1.0 · 2.5 or 0.001 to 0.04 (micro trim)						-							
Max. permissible differential pressure Δp	25 bar						-							
x_{FZ} value	0.65						-							

Table 3-4: Dimensions and weights for Type 42-24 and Type 42-28 · Balanced by a bellows

Nominal size	DN	15	20	25	32	40	50	65	80	100	125	150	200	250	
Length L		130	150	160	180	200	230	290	310	350	400	480	600	730	
Height H1	Up to 220 °C	225						300		355	460	590	730		
	Up to 350 °C	365						440		495	600	730	870		
Height H2	Forged steel	53	-	70	-	92	98	-							
	Cast steel	44			72			100		120	145	175	235	260	
Type 42-28 Differential Pressure Regulator															
Set points		Type 2428 Actuator													
0.2 bar	Height H ^{5) 6)}	390						465		520		-			
0.3 bar	Actuator	$\text{ØD} = 225 \text{ mm} \cdot A = 160 \text{ cm}^2$ ²⁾						$\text{ØD} = 285 \text{ mm} \cdot A = 320 \text{ cm}^2$		-					
0.4 bar															
0.5 bar	Weight ³⁾ in kg	11.5	12	13	19.5	20	22.5	38	43	57					
Type 42-24 Differential Pressure Regulator															
Set points		Type 2424 Actuator													
0.05 to 0.25 bar	Height H ^{5) 6) 7)}	610						685		740	990	1120	1260		
	Actuator	$\text{ØD} = 285 \text{ mm} \cdot A = 320 \text{ cm}^2$ ¹⁾						$\text{ØD} = 390 \text{ mm} \cdot A = 640 \text{ cm}^2$							
	Weight ³⁾ in kg	21	21.5	22.5	29	29.5	32	46	51	65	135	185	425	485	
0.1 to 0.6 bar	Height H ^{5) 6) 7)}	625						685		740	990	1120	1260		
	Actuator	$\text{ØD} = 225 \text{ mm} \cdot A = 160 \text{ cm}^2$ ²⁾						$\text{ØD} = 285 \text{ mm} \cdot A = 320 \text{ cm}^2$ ¹⁾		$\text{ØD} = 390 \text{ mm} \cdot A = 640 \text{ cm}^2$					
	Weight ³⁾ in kg	16	16.5	17.5	24	24.5	27	46	51	65	135	185	425	485	
0.2 to 1 bar	Height H ^{5) 6) 7)}	630						705		760	990	1120	1260		
	Actuator	$\text{ØD} = 225 \text{ mm} \cdot A = 160 \text{ cm}^2$ ²⁾						$\text{ØD} = 390 \text{ mm} \cdot A = 640 \text{ cm}^2$							
	Weight ³⁾ in kg	16	16.5	17.5	24	24.5	27	42	47	61	135	185	425	485	
0.5 to 1.5 bar	Height H ^{5) 6) 7)}	630						705		760	910	1040	1180		
	Actuator	$\text{ØD} = 225 \text{ mm} \cdot A = 160 \text{ cm}^2$ ²⁾						$\text{ØD} = 285 \text{ mm} \cdot A = 320 \text{ cm}^2$							
	Weight ³⁾ in kg	16	16.5	17.5	24	24.5	27	42	47	61	125	175	415	475	
1 to 2.5 bar	Height H ^{5) 6) 7)}	610						685		740	910	1040	1180		
	Actuator	$\text{ØD} = 225 \text{ mm} \cdot A = 160 \text{ cm}^2$													
	Weight ³⁾ in kg	16	16.5	17.5	24	24.5	27	42	47	61	125	175	415	475	
2 to 5 bar	Height H ^{5) 6) 7)}	590 · (710) ⁸⁾						665 · (785) ⁸⁾		720 · (840) ⁸⁾	825 · (945) ⁸⁾	955 · (1075) ⁸⁾	1095 · (1215) ⁸⁾		
	Actuator	$\text{ØD} = 170 \text{ mm} \cdot A = 80 \text{ cm}^2 \cdot (\text{ØD} = 225 \text{ mm} \cdot A = 160 \text{ cm}^2)$ ⁸⁾													
	Weight ³⁾ in kg	16	16.5	17.5	24	24.5	27	42	47	61	102	170	410	470	
4.5 to 10 bar ⁴⁾	Height H ^{5) 6) 7)}	710						785		840	945	1075	1215		
	Actuator	$\text{ØD} = 170 \text{ mm} \cdot A = 80 \text{ cm}^2$													
	Weight ³⁾ in kg	16	16.5	17.5	24	24.5	27	42	47	61	102	170	410	470	

1) Optionally with 640 cm² actuator

2) Optionally with 320 cm² actuator

3) The weight applies to version with EN-GJL-250. Add +10 % for all other materials.

4) DN 125 to 250: 4.5 to 10 bar on request

5) Minimum clearance required to remove the actuator: +100 mm · With extension piece: +140 mm

6) The height H increases to 200 mm at the maximum, depending on the extension piece used.

7) Actuators with metal cover H +135 mm

8) Sp. version A = 160 cm² without int. excess pressure limiter; with internal excess pressure limiter: H -50 mm

Design and principle of operation

Table 3-5: Dimensions and weights for Types 42-24 and 42-28 · Balanced by a diaphragm

Nominal size DN	65	80	100	125	150	200	250
Length L	290	310	350	400	480	600	730
Height H1	202		218	285	310	380	
Height H2	98		118	145	175	260	
Type 42-28 Differential Pressure Regulator							
Set points		Type 2428 Actuator					
0.2 bar	Height H ⁴⁾	355		375	-		
0.3 bar	Actuator	ØD = 285 mm · A = 320 cm ²					
0.4 bar	Weight [kg]	38	43	51	-		
0.5 bar							
Type 42-24 Differential Pressure Regulator							
Set points		Type 2424 Actuator					
0.05 to 0.25 bar	Height H ^{3) 4)}	720		740	815	840	910
	Actuator	ØD = 390 mm · A = 640 cm ²					
0.1 to 0.6 bar	Weight [kg]	42	47	55	75	95	250 270
	Height H ^{3) 4)}	575		595	815	840	910
	Actuator	ØD = 285 mm · A = 320 cm ^{2 1)}			ØD = 390 mm · A = 640 cm ²		
0.2 to 1 bar	Weight [kg]	42	47	55	75	95	250 270
	Height H ^{3) 4)}	575		595	735	760	830
	Actuator	ØD = 225 mm · A = 160 cm ^{2 2)}			ØD = 285 mm · A = 320 cm ^{2 1)}		
0.5 to 1.5 bar	Weight [kg]	42	47	55	75	95	250 270
	Height H ^{3) 4)}	575	575	595	735	760	830
	Actuator	ØD = 225 mm · A = 160 cm ^{2 2)}			ØD = 285 mm · A = 320 cm ^{2 1)}		
1 to 2.5 bar	Weight [kg]	42	47	55	75	95	250 270
	Height H ^{3) 4)}	575		590	735	760	830
	Actuator	ØD = 225 mm · A = 160 cm ^{2 2)}					
2 to 5 bar	Weight [kg]	42	47	55	75	95	250 270
	Height H ^{3) 4)}	575		595	735	760	830
	Actuator	ØD = 225 mm · A = 160 cm ²					

1) Optionally with 640 cm² actuator

2) Optionally with 320 cm² actuator

3) Actuators with metal cover H +135 mm

4) Minimum clearance required to remove the actuator: +100 mm

Table 3-6: Weights of Type 2424 and Type 2428 Actuators · Weights in kg (without process medium)

Actuator area in cm ²	640	320	160 · 80 · 40
Weight ¹⁾ in kg	45	23	12

1) Weight of Type 2424 Actuator with two diaphragms on request

Dimensional drawings

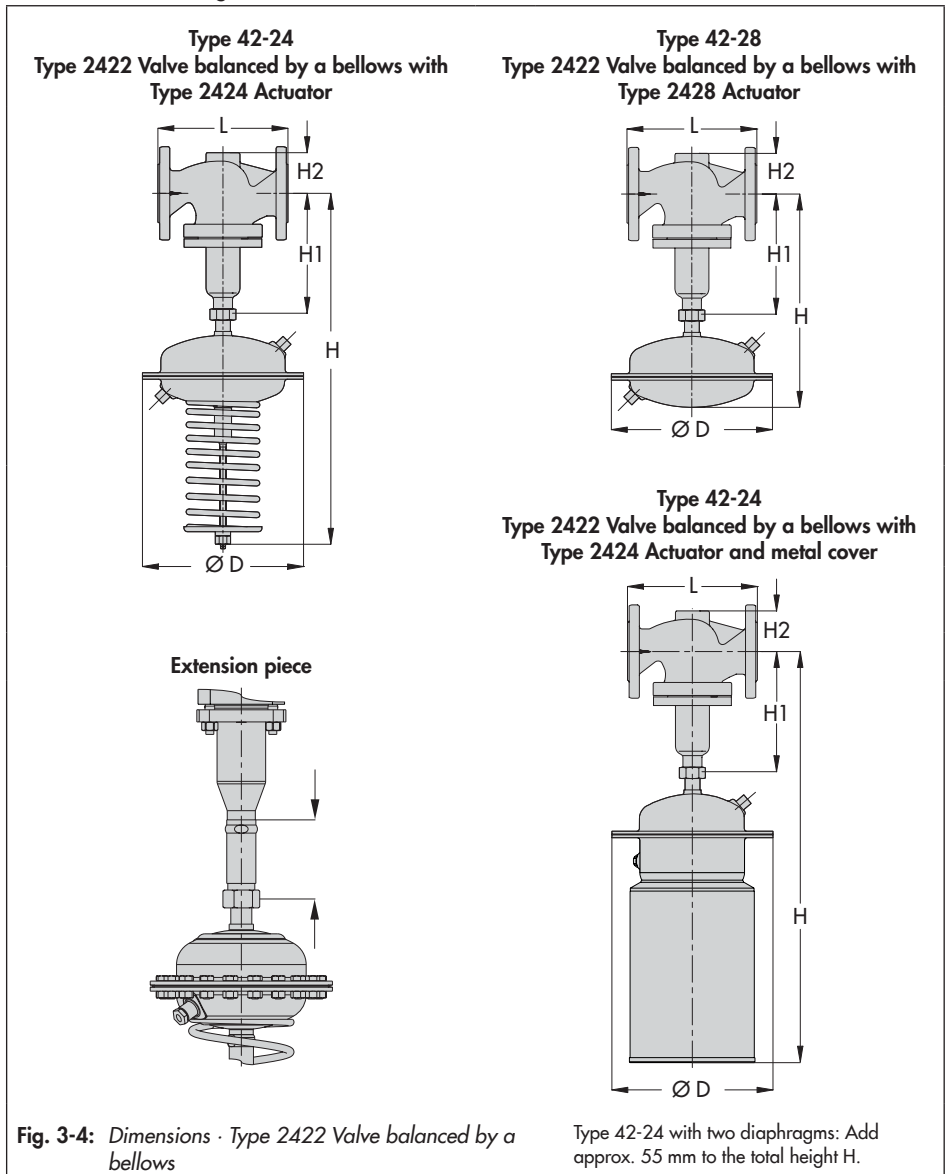

Design and principle of operation

Dimensional drawings

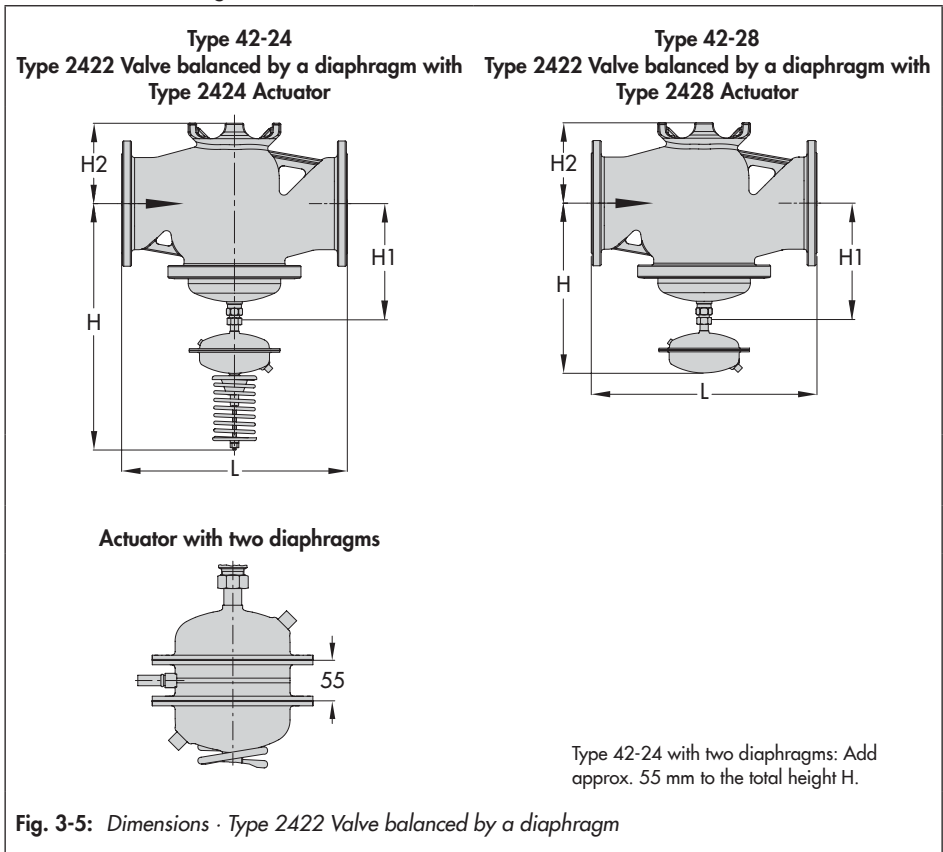

Fig. 3-5: Dimensions · Type 2422 Valve balanced by a diaphragm

4 Shipment and on-site transport

The work described in this chapter is only to be performed by personnel appropriately qualified to carry out such tasks.

4.1 Accepting the delivered goods

After receiving the shipment, proceed as follows:

1. Check the scope of delivery. Check that the specifications on the valve and actuator nameplate match the specifications in the delivery note. See the 'Markings on the device' chapter for nameplate details.
2. Check the shipment for transportation damage. Report any damage to SAMSON and the forwarding agent (refer to delivery note).
3. Determine the weight and dimensions of the units to be lifted and transported in order to select the appropriate lifting equipment and lifting accessories. Refer

to the transport documents and the 'Design and principle of operation' chapter.

4.2 Removing the packaging from the regulator

The components (valve, actuator and, if applicable, accessories) of the regulator are delivered separately.

Proceed as follows to lift and install the valve:

- Do not open or remove the packaging until immediately before lifting to install the regulator into the pipeline.
- Leave the regulator components in its transport container or on the pallet to transport it on site.
- Do not remove the protective caps from the inlet and outlet until immediately before installing the valve into the pipeline.

Shipment and on-site transport

They prevent foreign particles from entering the valve.

- Dispose and recycle the packaging in accordance with the local regulations.

4.3 Transporting and lifting the regulator

⚠ DANGER

Danger due to suspended loads falling.

- Stay clear of suspended or moving loads.
- Close off and secure the transport paths.

⚠ WARNING

Risk of injury due to incorrect lifting without the use of lifting equipment.

Lifting the regulator without the use of lifting equipment may lead to injuries (back injury in particular) depending on the weight of the regulator and/or actuator.

- Observe the occupational health and safety regulations valid in the country of use.
- Observe the guideline weight for manual handling: 15 to max. 55 kg per person taking into account age, gender and physical fitness.
- When the actuator is filled with medium, take the weight of the medium also into account.
- Refer to the 'Design and principle of operation' chapter for the weights of the regulator and actuator.

⚠ WARNING

Risk of personal injury due to the regulator tipping.

- Observe the regulator's center of gravity.
- Secure the regulator against tipping over or turning.

⚠ WARNING

Risk of lifting equipment tipping over and risk of damage to lifting accessories due to exceeding the rated lifting capacity.

- Only use approved lifting equipment and accessories whose minimum lifting capacity is higher than the weight of the valve (including actuator and packaging, if applicable).
- Refer to the 'Design and principle of operation' chapter for the weights.

💡 Tip

Our after-sales service can provide more detailed transport and lifting instructions on request.

4.3.1 Transporting the regulator

The regulator can be transported using lifting equipment (e.g. crane or forklift).

- Leave the regulator in its transport container or on the pallet to transport it.
- Observe the transport instructions.

Transport instructions

- Protect the regulator against external influences (e.g. impact).
- Do not damage the corrosion protection (paint, surface coatings). Repair any damage immediately.
- Protect the regulator against moisture and dirt.
- Protect the piping and any mounted valve accessories against damage.
- The permissible ambient temperature of standard regulators is -20 to $+80$ °C.

4.3.2 Lifting the regulator

To install a large regulator into the pipeline, use lifting equipment (e.g. crane or forklift) to lift it.

Lifting instructions

- Use a hook with safety latch to secure the slings from slipping off the hook during lifting and transporting (see Fig. 4-1).
- Secure slings against slipping.
- Make sure the slings can be removed after installation.
- Prevent the regulator from tilting or tipping.
- Do not leave loads suspended when interrupting work for longer periods of time.
- Make sure that the axis of the pipeline is always horizontal during lifting and the axis of the plug stem is always vertical.

Lifting

1. Attach one sling to the flange of the body and to the rigging equipment (e.g. hook) of the crane or forklift (see Fig. 4-1).
2. Carefully lift the regulator. Check whether the lifting equipment and accessories can bear the weight.
3. Move the regulator at an even pace to the site of installation.
4. Install the regulator into the pipeline (see the 'Installation' chapter).
5. After installation in the pipeline, check whether the regulator flanges are bolted tight.
6. Remove slings.

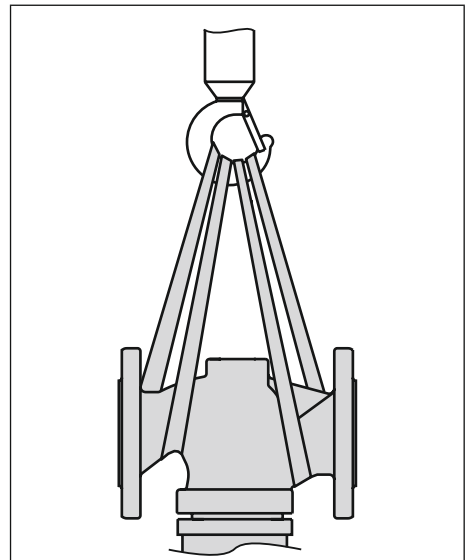

Fig. 4-1: Schematic drawing of lifting points on the regulator

- The permissible storage temperature of standard regulators is -20 to $+65$ °C.
- Do not place any objects on the regulator.

4.4 Storing the regulator

NOTICE

Risk of regulator damage due to improper storage.

- Observe the storage instructions.
- Avoid long storage times.
- Contact SAMSON in case of different storage conditions or longer storage times.

Note

We recommend regularly checking the regulator and the prevailing storage conditions during long storage periods.

Special storage instructions for elastomers

Elastomer, e.g. operating diaphragm

- To keep elastomers in shape and to prevent cracking, do not bend them or hang them up.
- Store elastomers away from lubricants, chemicals, solutions and fuels.
 - We recommend a storage temperature of 15 °C for elastomers.

Tip

SAMSON's After-sales Service can provide more detailed storage instructions on request.

Storage instructions

- Protect the regulator against external influences (e.g. impact).
- Secure the regulator in the stored position against slipping or tipping over.
- Do not damage the corrosion protection (paint, surface coatings). Repair any damage immediately.
- Protect the regulator against moisture and dirt. Store it at a relative humidity of less than 75 %. In damp spaces, prevent condensation. If necessary, use a drying agent or heating.
- Make sure that the ambient air is free of acids or other corrosive media.

5 Installation

The work described in this chapter is to be performed only by personnel appropriately qualified to carry out such tasks.

5.1 Installation conditions

Work position

The work position for the regulator is the front view onto all operating controls on the regulator (including any additional fittings) seen from the position of operating personnel.

Plant operators must ensure that, after installation of the device, the operating personnel can perform all necessary work safely and easily access the device from the work position.

Pipeline routing

The inlet and outlet lengths vary depending on several variables and process conditions and are intended as recommendations. Contact SAMSON if the lengths are significantly shorter than the recommended lengths.

To ensure that the regulator functions properly, proceed as follows:

- Observe the inlet and outlet lengths (see Table 5-1). Contact SAMSON if the regulator conditions or state of the medium process deviate.

- Install the regulator free of stress and with the least amount of vibrations as possible. Read information under “Mounting position” and “Support or suspension” in this chapter.
- For media with a tendency to condensate, an automatic drainage must be installed. Install the pipeline with a slight downward slope on both sides of the regulator to prevent condensate from collecting in the valve.
- Install the regulator allowing sufficient space to remove the actuator and valve or to perform service work on them.

Mounting position

To ensure that the regulator functions properly, proceed as follows:

- Standard mounting position: install the actuator housing suspended downward in horizontal pipelines (see Fig. 5-1).
- Make sure the direction of flow matches the direction indicated by the arrow on the body.
- Contact SAMSON if the mounting position is not as specified above.

NOTICE

Damage due to freezing.

Protect the regulator from icing up when controlling media that can freeze. Unless the regulator is installed in locations where no frost occurs, remove the regulator from the pipeline when the plant is shut down.

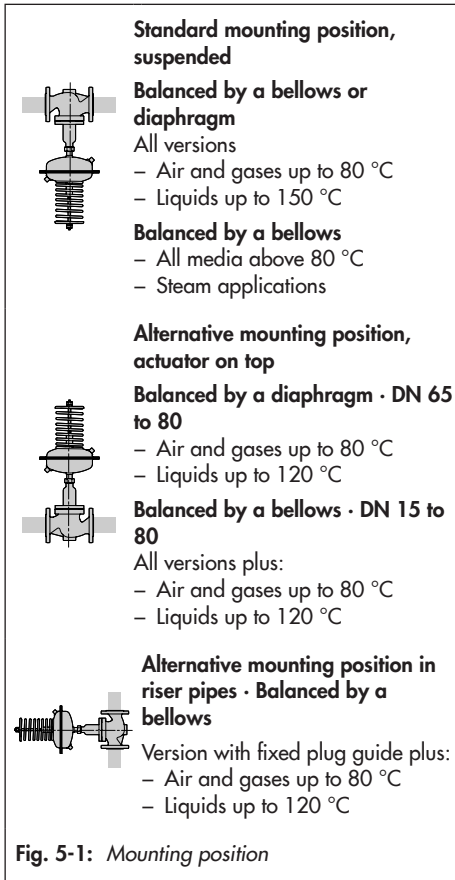

Support or suspension

i Note

The plant engineering company is responsible for selecting and implementing a suitable support or suspension of the installed regulator and the pipeline.

Depending on the regulator version and mounting position, the valve, actuator and pipeline must be supported or suspended.

! NOTICE

Risk of regulator damage due to incorrect support.

- Do not attach supports to the valve, to moving parts on the actuator or to the control lines.
- Contact SAMSON if the mounting position differs from the standard mounting position.

Control line

Route the control lines on site preferably using a 8x1 mm (stainless) steel pipe. The pressure tapping point must at least three times the nominal size (DN) away from any pipe fittings (e.g. restrictions, bends or branches), that may cause turbulence in the flow. How the lines are routed generally depends on the installation site.

- Preferably connect the control line to the side of the main pipe (see Fig. 5-2 and Fig. 5-3).
- Do not change the pipe diameter of the main pipeline with an eccentric reducer.

💡 Tip

Control line kits, needle valves, condensation chambers and compression-type screw fittings can be supplied as required. These accessories are listed in ► T 3095.

Needle valve

To additionally dampen the regulator or to shut off the control lines, we recommend also installing a needle valve in the control line in addition to the standard SAMSON screw joint with restriction. The standard SAMSON screw joint with restriction is located in the compression-type fitting at the (+) connection of the diaphragm actuator.

Compensation chamber

A compensation chamber (18) is required for liquids above 150 °C as well as for steam (see Fig. 5-4). Install the compensation chamber at the highest point of the pipeline. The mounting position of the compensation chamber is indicated by an adhesive label on the chamber itself as well as by an arrow and the word "top" stamped on the top of the chamber.

This mounting position must be adhered to; otherwise the safe functioning of the regulator cannot be guaranteed.

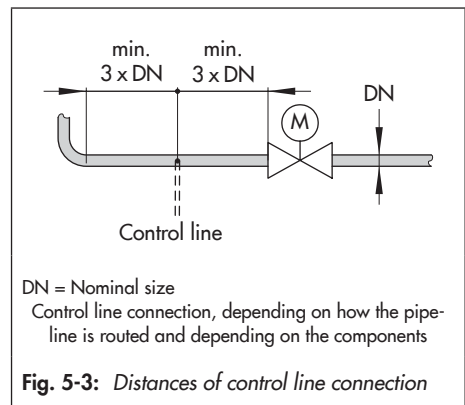
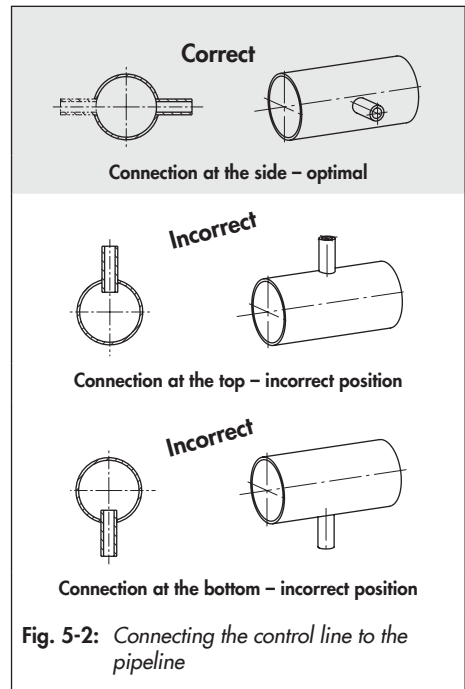

5.2 Preparation for installation

Valve and actuator can be assembled before or after the valve has been installed in the pipeline. We recommend first installing the valve without the actuator into the pipeline.

Before installation, make sure the following conditions are met:

- The valve is clean.
- The valve, actuator and all piping are not damaged.
- Install a strainer upstream of the regulator.
- The valve data on the nameplate (type designation, nominal size, material, pressure rating and temperature range) match the plant conditions (size and pressure rating of the pipeline, medium temperature etc.). See the 'Markings on the device' chapter for nameplate details.
- The requested or required additional fittings (see the 'Design and principle of operation' chapter) have been installed or prepared as necessary before installing the valve.

Proceed as follows:

- Lay out the necessary material and tools to have them ready during installation work.
- Flush the pipeline **before** installing the regulator (see section "Cleaning the pipeline").
- The plant operator is responsible for cleaning the pipelines in the plant.

- For steam applications, dry the pipelines. Moisture will damage the inside of the regulator.
- Check any mounted pressure gauges to make sure they function properly.

5.2.1 Cleaning the pipeline

We recommend additionally flushing the pipeline without an installed regulator over a time period of several minutes before start-up. In this case, install a suitable length of pipe into the pipeline in place of the regulator.

- All required control lines are connected and not shut off.
- Before flushing the plant with the process medium, read the information under 'Starting up the plant' in the 'Start-up' chapter.
- A higher set point is adjusted at the controller and all consumers are open to guarantee a high flow rate.
- Observe the mesh size of the upstream strainer for the maximum particle size. Use strainers to suit the process medium.
- Check the strainer for dirt each time the pipeline is flushed and clean it, if necessary.

Table 5-1: Inlet and outlet lengths

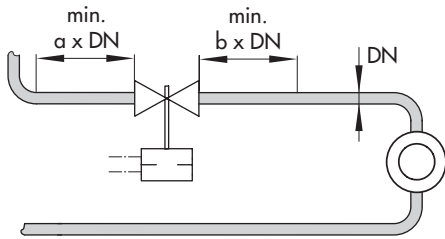

State of process medium	Valve conditions	Inlet length a	Outlet length b
Gas	$Ma \leq 0.3$	2	4
Vapors ¹⁾	$Ma \leq 0.3$	2	4
Liquid	Free of cavitation/ $w < 3 \text{ m/s}$	2	4
	Cavitation producing noise/ $w \leq 3 \text{ m/s}$	2	4

a Inlet length
b Outlet length

¹⁾ No wet steam

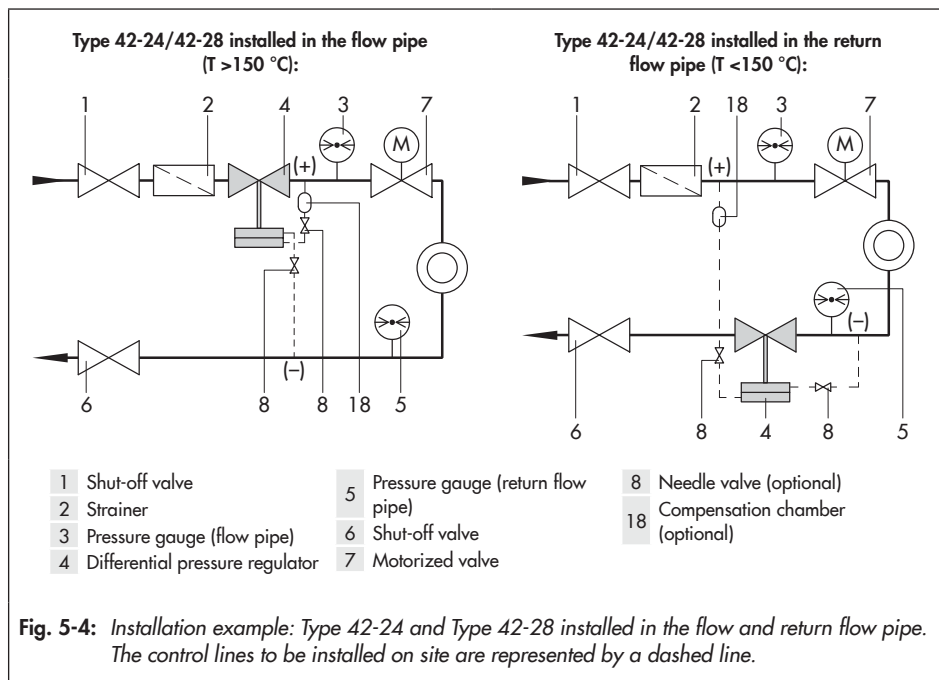

5.3 Installation

The components (valve, actuator and, if applicable, accessories) of the SAMSON regulator are delivered separately. Upon delivery, the separate components must be assembled together. The activities listed below are necessary for installation and before start-up of the regulator.

⚠ DANGER

Danger due to suspended loads falling.

- Stay clear of suspended or moving loads.
 - Close off and secure the transport paths.
-

⚠ WARNING

Risk of injury due to incorrect lifting without the use of lifting equipment.

Lifting the regulator without the use of lifting equipment may lead to injuries (back injury in particular) depending on the weight of the regulator and/or actuator.

- Observe the guideline weight for manual handling: 15 to max. 55 kg per person taking into account age, gender and physical fitness.
 - When the actuator is filled with medium, take the weight of the medium also into account.
 - Refer to the 'Design and principle of operation' chapter for the weights of the regulator and actuator.
 - Observe the occupational health and safety regulations valid in the country of use.
-

⚠ WARNING

Risk of lifting equipment tipping over and risk of damage to lifting accessories due to exceeding the rated lifting capacity.

- Only use approved lifting equipment and accessories whose minimum lifting capacity is higher than the weight of the valve (including actuator and packaging, if applicable).
 - Refer to the 'Design and principle of operation' chapter for the weights.
-

⚠ WARNING

Risk of personal injury due to the regulator tipping.

- Observe the regulator's center of gravity.
 - Secure the regulator against tipping over or turning.
-

ⓘ NOTICE

Risk of regulator damage due to the use of unsuitable tools.

- Only use tools approved by SAMSON (see 'Tools' in the Appendix).
-

ⓘ NOTICE

Risk of regulator damage due to the use of unsuitable lubricants.

- Only use lubricants approved by SAMSON (see 'Lubricants' in the Appendix).
-

NOTICE**Risk of regulator damage due to excessively high or low tightening torques.**

Observe the specified torques when tightening regulator components. Excessive tightening torques lead to parts wearing out more quickly. Parts that are too loose may cause leakage.

→ Observe the specified tightening torques (see 'Tightening torques' in the Appendix).

5.3.1 Installing the regulator

The regulator can be installed into the downstream pressure pipe (return flow pipe) or the upstream pressure pipe (flow pipe) of the plant. See installation examples in Fig. 5-4.

1. Close the shut-off valves (1, 6) upstream and downstream of the regulator while the regulator is being installed.
2. Remove the protective caps from the valve ports before installing the valve.
3. Lift the valve using suitable lifting equipment to the site of installation. Observe the flow direction through the valve. The arrow on the valve indicates the direction of flow.
4. Make sure that the correct flange gaskets are used.
5. Bolt the pipe to the valve free of stress.
6. Mount the actuator.
 - Fasten the actuator on the valve by tightening the coupling nut (11), while observing the alignment of the control line

connections. Observe the specified tightening torques (see 'Tightening torques' in the Appendix).

7. Mount the control lines (to be installed on site) and any needle valves and open them.
 - Mount the control lines (to be installed on site) on the actuator. Observe the specified tightening torques (see 'Tightening torques' in the Appendix).
 - For **steam** or **liquids above 150 °C** install the compensation chamber and fill it with the process medium. Observe the specified tightening torques (see 'Tightening torques' in the Appendix).

5.3.2 Filling the plant

For liquids and gases

Open the shut-off valves slowly over a time period of several minutes preferably starting from the upstream pressure side to fill the plant (all consumers are open).

- Make sure that the pressure rises simultaneously upstream and downstream of the regulator to avoid damaging the balancing bellows.
- Avoid pressure surges.

NOTICE

Risk of regulator damage due to steam hammering.

Steam hammering is possible when the process medium is a liquid with a boiling point at atmospheric pressure.

- Open the shut-off valves slowly preferably starting from the downstream side to fill the plant over a time period of several minutes.

For steam and vapors

- Completely drain and dry steam lines to prevent water hammering.
- Slowly allow the steam to enter the plant to ensure that the pipes and valves warm up evenly and to avoid excessive flow velocities.
- Drain off any condensate that has collected in the pipeline during start-up.
- Avoid pressure surges.

5.4 Testing the regulator

⚠ DANGER

Risk of bursting due to incorrect opening of pressurized equipment or components.

Regulators and pipelines are pressure equipment that may burst when handled incorrectly. Flying projectile fragments or the release of process medium under pressure can cause serious injury or even death.

Before working on the regulator:

- Depressurize all plant sections concerned and the regulator.
- Disconnect the control line.
- Drain the process medium from all the plant sections concerned as well as the valve.

⚠ WARNING

Risk of personal injury due to pressurized components and process medium being discharged.

Incorrect opening of pressure equipment or mounting parts may lead to the process medium escaping to the atmosphere.

- Do not loosen the control line while the valve is pressurized.
- Do not start up the regulator until all parts have been mounted.

⚠ WARNING

Risk of hearing loss or deafness due to loud noise.

Noise emission (e.g. cavitation) may occur during operation caused by the process medium and the operating conditions.

→ Wear hearing protection when working near the valve. Follow the instructions given by the plant operator.

⚠ WARNING

Risk of burn injuries due to hot or very cold components and pipelines.

Depending on the process medium, valve components and pipelines may get very hot or cold and cause burn injuries.

→ Wear protective clothing and safety gloves.

The regulator components are delivered by SAMSON ready for use. To test the regulator functioning before start-up or putting back the regulator into operation, perform the following tests:

5.4.1 Leakage

The plant operator is responsible for performing the leak test and selecting the test method. The leak test must comply with the requirements of the national and international standards that apply at the site of installation.

💡 Tip

SAMSON's After-sales Service can support you to plan and perform a leak test for your plant.

- All required control lines are connected to the actuator and are not shut off.
1. Install the regulator into the pipeline. See section "Installation".
 2. Apply the required test pressure.
 3. Check the regulator for leakage to the atmosphere.
 4. Depressurize the pipeline section and regulator.
 5. Rework any parts that leak and repeat the leak test.

5.4.2 Pressure test

i Note

The plant operator is responsible for performing the pressure test. SAMSON's After-sales Service can support you to plan and perform a pressure test for your plant.

! NOTICE

Risk of valve damage due to a sudden pressure increase.

– Slowly open the shut-off valves.

Pressure test with mounted diaphragm actuator

During the pressure test, make sure the following conditions are met:

- All required control lines are connected to the actuator and are not shut off.
- Do not allow the pressure to exceed the 1.5 times the pressure rating of the valve body.
- Do not apply a pressure higher than the maximum specified pressure rating or maximum operating pressure to the actuator (see 'Technical data' in the 'Design and principle of operation' chapter).
- Make sure that the pressure rises simultaneously upstream and downstream of the regulator to avoid damaging the balancing bellows or the balancing diaphragm.

If the **test pressure** of the valve is **higher** than the specified maximum permissible operating pressure of the diaphragm actuator:

- Depressurize the plant and remove the control line. Close any control line connection in the plant by closing the installed shut-off valve or inserting a blanking plug.
- Seal the body connections with blanking plugs.

The diaphragm actuator remains mounted on the valve and seals off the valve.

Pressure test without mounted diaphragm actuator

! WARNING

Risk of personal injury due to pressurized components and process medium being discharged.

Incorrect opening of pressure equipment or mounting parts may lead to the process medium escaping to the atmosphere.

- Do not loosen the control line while the valve is pressurized.
- Do not start up the regulator until all parts have been mounted.

If the valve is not sealed off, the test medium escapes at the connection where the actuator is connected to the valve. It is not possible to perform a pressure test on the valve in this case (see Fig. 5-5).

- Seal off the valve using a coupling nut (0250-1037) with seal (0340-1962).

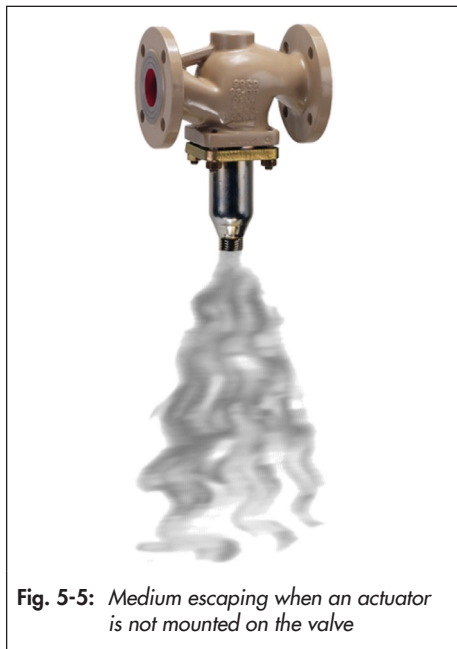

Fig. 5-5: *Medium escaping when an actuator is not mounted on the valve*

5.5 Insulation

To insulate cold systems, we recommend first filling the plant and carefully rinsing it. The regulator must not yet be insulated at this stage.

1. Start up the plant and adjust the set point (see the 'Start-up' chapter).
2. Shut down the plant again and let it heat up until the condensation water has dried off.
3. Insulate the regulator and pipes conveying the process medium using insulation material with a water vapor barrier. Use a stable sleeve to protect the external set point springs against touching or friction and include it in the insulation. If a control line is to be routed through the insulation, special care must be taken with the sealing since slight changes in shape may occur. The insulation thickness depends on the medium temperature and the ambient conditions. 50 mm is a typical thickness.

⚠ NOTICE

Risk of regulator damage due to incorrect insulation.

- ➔ *The actuator must be insulated for medium temperatures below 0 °C.*
 - ➔ *The regulator must only be insulated up to the bottom section with balancing bellows or up to the connection of the actuator for medium temperatures above 80 °C.*
-

6 Start-up

The work described in this chapter is only to be performed by personnel appropriately qualified to carry out such tasks.

⚠ WARNING

Risk of personal injury due to pressurized components and process medium being discharged.

Incorrect opening of pressure equipment or mounting parts may lead to the process medium escaping to the atmosphere.

- *Do not loosen the control line while the valve is pressurized.*
- *Do not start up the regulator until all parts have been mounted.*

⚠ WARNING

Risk of burn injuries due to hot or cold components and pipeline.

Regulator components and the pipeline may become very hot or cold. Risk of burn injuries.

- *Allow components and pipelines to cool down or warm up to the ambient temperature.*
- *Wear protective clothing and safety gloves.*

⚠ WARNING

Risk of hearing loss or deafness due to loud noise.

Noise emission (e.g. cavitation) may occur during operation caused by the process medium and the operating conditions.

- *Wear hearing protection when working near the valve. Follow the instructions given by the plant operator.*

Before start-up or putting the device back into service, make sure the following conditions are met:

- The regulator is properly installed into the pipeline (see the 'Installation' chapter).
- The leak and function tests have been completed successfully (see the 'Testing the regulator' chapter).
- The prevailing conditions in the plant section concerned meet the regulator sizing requirements (see information under 'Intended use' in the 'Safety instructions and measures' chapter).

6.1 Start-up and putting the device back into operation

1. Depending on the field of application, allow the regulator to cool down or warm up to reach ambient temperature before start up.
2. All consumer valves are open.
3. Open the shut-off valves slowly over a time period of several minutes. Slowly opening these valves prevents a sudden surge in pressure which can damage the regulator parts.
4. Check the regulator to ensure it functions properly (see information under 'Adjusting the differential pressure set point' in the 'Operation' chapter).

Start-up

Before starting up the plant, make sure the following conditions are met:

- The control lines are open (needle valve) and correctly connected.

6.2 Starting up the plant

WARNING

Risk of personal injury due to process medium escaping.

Depending on the conditions in the plant in operation, it may be necessary to install compensation chambers to protect the regulator.

→ Proceed as described in 'Regulation of liquids' and 'Regulation of steam' for liquids or steam above 150 °C before starting up the plant.

1. The plant (e.g. consumer valve) must be open while the plant is being filled.
2. The control lines are open (needle valve) and correctly connected.

3. **For media that do not reach their boiling point:**

Open the shut-off valves **slowly** over a time period of several minutes starting from the upstream pressure side. Fill the plant with the medium.

For media that reach their boiling point:

Open the shut-off valves **slowly** starting from the downstream side to avoid steam hammering.

4. Make sure that the pressure rises simultaneously upstream and downstream of the

regulator to avoid damaging the balancing bellows or diaphragm.

Regulation of liquids

→ For liquid medium temperatures above 150 °C, first fill the compensation chamber with the process medium. Proceed as follows:

1. Unscrew filler plug from the compensation chamber.
2. Use the included plastic funnel or a jug to pour in the process medium until it reaches the filling opening.
3. Screw the filler plug back in and tighten it.

Regulation of steam

→ Warm up the plant very slowly. During this procedure, drain off any condensate and vent the plant.

→ First fill the compensation chamber with water. Proceed as follows:

1. Unscrew filler plug from the compensation chamber.
 2. Use the included plastic funnel or a jug to pour in water until it reaches the filling opening.
 3. Screw the filler plug back in and tighten it.
- All pipes conveying the process medium must be completely drained and dry.
 - Air and condensate must be allowed to escape from the plant.
 - Allow time for the pipes and valves to heat up.

7 Operation

Immediately after completing start-up or placing the regulator back into service (see the 'Start-up' chapter), the regulator is ready for use.

⚠ WARNING

Risk of burn injuries due to hot or cold components and pipeline.

Regulator components and the pipeline may become very hot or cold. Risk of burn injuries.

- Allow components and pipelines to cool down or warm up to the ambient temperature.
- Wear protective clothing and safety gloves.

⚠ WARNING

Risk of personal injury due to pressurized components and process medium being discharged.

Incorrect opening of pressure equipment or mounting parts may lead to the process medium escaping to the atmosphere.

- Do not loosen the control line while the valve is pressurized.
- Do not start up the regulator until all parts have been mounted.

⚠ WARNING

Risk of hearing loss or deafness due to loud noise.

Noise emission (e.g. cavitation) may occur during operation caused by the process medium and the operating conditions.

- Wear hearing protection when working near the valve. Follow the instructions given by the plant operator.

7.1 Adjusting the differential pressure set point

- The control and shut-off valves as well as all consumers or a bypass valve (if installed) must be open.

i Note

We recommend adjusting the regulator at an operating point at which the consumer valve is open by approximately 5 %. This results in the highest controlled differential pressure.

Type 42-24

Adjust the required set point by tensioning the set point springs at the set point adjuster (17).

For smaller differential pressure set points, we recommend using a differential pressure pressure gauge instead of the pressure gauges (3 and 5) to check the pressure. See Fig. 7-1.

Operation

- Turn the set point adjuster (17) clockwise (↻) to increase the pressure set point.
- Turn the set point adjuster (17) counter-clockwise (↺) to reduce the pressure set point.

Change the plant throughput (e.g. by opening and closing the consumer valve) to check the adjusted differential pressure at the regulator. Correct it, if necessary.

Type 42-28

The fixed set point is ready adjusted at the set point springs in the actuator. Depending on the set point springs, a differential pressure of 0.2 to 0.5 bar (in 0.1 bar increments) can be selected at the ordering stage.

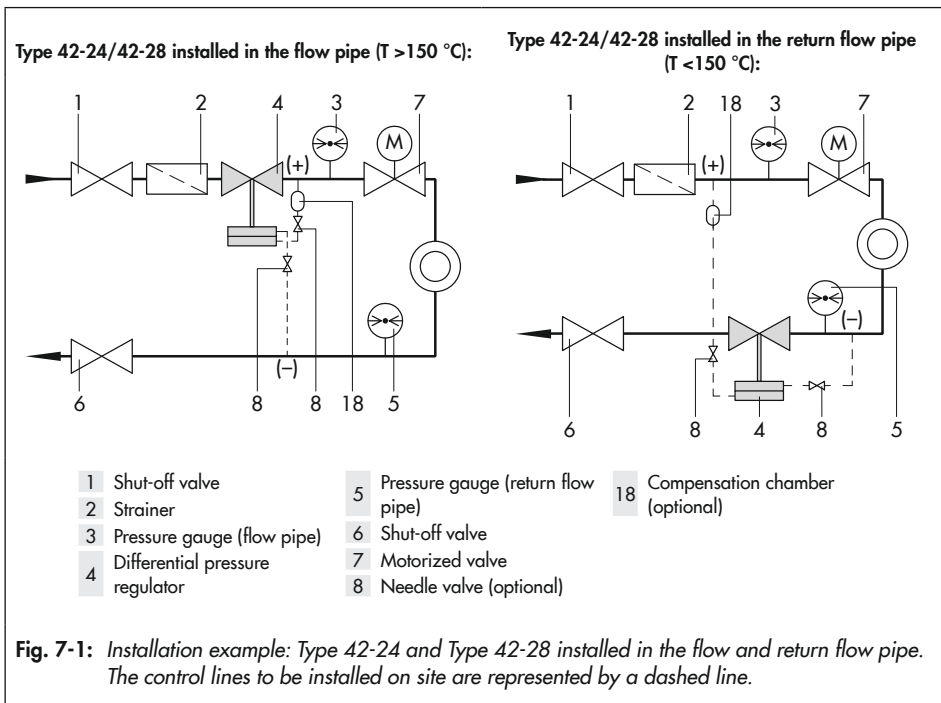

8 Malfunctions

8.1 Troubleshooting

Malfunction	Possible reasons	Recommended action
Differential pressure exceeds adjusted set point.	Insufficient pressure pulses on the operating diaphragm	→ Clean the control line and screw fittings.
	Foreign particles blocking the plug	→ Remove foreign particles. → Replace damaged parts. → Contact SAMSON's After-sales Service.
	Seat and plug are worn or leak.	→ Replace the damaged seat and plug. → Contact SAMSON's After-sales Service.
	Regulator or K_{VS}/C_V coefficient too small	→ Check the sizing. → Change K_{VS}/C_V coefficient, if necessary or install a different sized regulator. → Contact SAMSON's After-sales Service.
	Safety device, e.g. pressure limiter, has been triggered	→ Check plant. If necessary, unlock safety device.
	Pressure tapped at the wrong place.	→ Reconnect control lines at a different place. Do not tap pressure at pipe bends or necks.
	Defective operating diaphragm	→ Replace damaged diaphragm.
Differential pressure set point not reached	Regulator installed against the flow	→ Install the regulator so that the direction of flow matches the direction indicated by the arrow on the body.
	Regulator or K_{VS}/C_V coefficient too large	→ Check the sizing. → Change K_{VS}/C_V coefficient, if necessary or install a different sized regulator. → Contact SAMSON's After-sales Service.
	Incorrect set point range selected	→ Check set point range → Contact SAMSON's After-sales Service.
	Foreign particles blocking the plug	→ Remove foreign particles. → Replace damaged parts. → Contact SAMSON's After-sales Service.
	Control line blocked	→ Clean the control line and screw fittings.
	Strainer blocked	→ Clean the strainer.

Malfunctions

Malfunction	Possible reasons	Recommended action
Differential pressure fluctuates.	Regulator or K_{VS}/C_V coefficient too large	<ul style="list-style-type: none"> → Check the sizing. → Change K_{VS}/C_V coefficient, if necessary or install a different sized regulator. → Contact SAMSON's After-sales Service.
	The restriction in the control line for pressure tapping is too large or missing.	<ul style="list-style-type: none"> → Install a restriction. → Install a smaller restriction.
Slow control response	Restriction in the screw joint of the actuator dirty or too small	<ul style="list-style-type: none"> → Do not close the screw joint with restriction completely. → Clean screw joint or install larger screw joint.
	Dirt in the control line	<ul style="list-style-type: none"> → Clean the control line.
Jerky control response	Increased friction, e.g. due to foreign particles between seat and plug	<ul style="list-style-type: none"> → Remove foreign particles. → Replace damaged parts. → Contact SAMSON's After-sales Service.
Loud noises	High flow velocity, cavitation	<ul style="list-style-type: none"> → Check the sizing. → Install larger regulator, if necessary.

i Note

Contact SAMSON's After-sales Service for malfunctions not listed in the table.

The malfunctions listed in Chapter 8.1 are caused by mechanical faults and incorrect regulator sizing. In the simplest case, the functioning can be restored following the recommended action. Special tools may be required to rectify the fault.

Exceptional operating and installation conditions may lead to changed situations that may affect the control response and lead to malfunctions. For troubleshooting, the conditions, such as installation, process medium, temperature and pressure conditions, must be taken into account.

**Tip**

SAMSON's After-sales Service can support you in drawing up an inspection and test plan for your plant.

8.2 Emergency action

Plant operators are responsible for emergency action to be taken in the plant.

We recommend removing the regulator from the pipeline before repairing it.

In the event of a regulator malfunction:

1. Close the shut-off valves upstream and downstream of the regulator to stop the process medium from flowing through the regulator.
2. Perform troubleshooting (see Chapter 8.1).
3. Rectify those malfunctions that can be remedied based on the instructions provided here. Contact SAMSON's After-sales Service in all other cases.

Putting the regulator back into operation after a malfunction

See the 'Start-up' chapter.

9 Servicing

The regulator does not require any maintenance. Nevertheless, it is subject to natural wear, particularly at the seat, plug and operating diaphragm. Depending on the operating conditions, check the regulator at regular intervals to avoid possible malfunctions.

Plant operators are responsible for drawing up an inspection and test plan. Details on faults and how to remedy them can be found in the 'Malfunctions' chapter.

The work described in this chapter is only to be performed by personnel appropriately qualified to carry out such tasks.

We recommend removing the regulator from the pipeline before performing any maintenance or service work.

⚠ DANGER

Danger due to suspended loads falling.

- Stay clear of suspended or moving loads.
- Close off and secure the transport paths.

⚠ WARNING

Risk of burn injuries due to hot or cold components and pipeline.

Regulator components and the pipeline may become very hot or cold. Risk of burn injuries.

- Allow components and pipelines to cool down or warm up to the ambient temperature.
- Wear protective clothing and safety gloves.

⚠ WARNING

Risk of personal injury due to residual process medium in the regulator.

While working on the regulator, residual process medium can escape and, depending on its properties, may lead to personal injury, e.g. (chemical) burns.

- Wear protective clothing, safety gloves and eye protection.

⚠ WARNING

Risk of personal injury due to the regulator tipping.

- Observe the regulator's center of gravity.
- Secure the regulator against tipping over or turning.

⚠ WARNING

Risk of injury due to incorrect lifting without the use of lifting equipment.

Lifting the regulator without the use of lifting equipment may lead to injuries (back injury in particular) depending on the weight of the regulator and/or actuator.

- Observe the occupational health and safety regulations valid in the country of use.
- Observe the guideline weight for manual handling: 15 to max. 55 kg per person taking into account age, gender and physical fitness.
- When the actuator is filled with medium, take the weight of the medium also into account.

Servicing

→ Refer to the 'Design and principle of operation' chapter for the weights of the regulator and actuator.

⚠ WARNING

Risk of lifting equipment tipping over and risk of damage to lifting accessories due to exceeding the rated lifting capacity.

- Only use approved lifting equipment and accessories whose minimum lifting capacity is higher than the weight of the valve (including actuator and packaging, if applicable).
 - Refer to the 'Design and principle of operation' chapter for the weights.
-

ⓘ NOTICE

Risk of regulator damage due to excessively high or low tightening torques.

Observe the specified torques when tightening regulator components. Excessive tightening torques lead to parts wearing out more quickly. Parts that are too loose may cause leakage.

- Observe the specified tightening torques (see 'Tightening torques' in the Appendix).
-

ⓘ NOTICE

Risk of regulator damage due to the use of unsuitable tools.

- Only use tools approved by SAMSON (see 'Tools' in the Appendix).
-

ⓘ NOTICE

Risk of regulator damage due to the use of unsuitable lubricants.

- Only use lubricants approved by SAMSON (see 'Lubricants' in the Appendix).
-

i Note

The regulator was checked by SAMSON before it left the factory.

- Certain test results certified by SAMSON lose their validity when the regulator is opened. Such testing includes seat leakage and leak tests.
 - The product warranty becomes void if service or repair work not described in these instructions is performed without prior agreement by SAMSON's After-sales Service.
 - Only use original spare parts by SAMSON, which comply with the original specifications.
-

💡 Tip

SAMSON's After-sales Service can support you in drawing up an inspection and test plan for your plant.

Legend for Fig. 9-1 and Fig. 9-2

- 1 Valve body
- 2 Seat
- 3 Plug
- 4 Plug stem
- 5 Balancing bellows
- 5.1 Balancing diaphragm (DN 65 to 250)
- 11 Coupling nut
- 12 Diaphragm stem with force limiter
- 13 Operating diaphragm
- 14 Bottom diaphragm case (valve on top)
- 15 Nuts and bolts
- 16 Set point springs
- 17 Set point adjuster
- 18 Nut
- 19 Diaphragm plate
- 20 Control line
- 21 Overload protection (internal excess pressure limiter)
- 22 Diaphragm stem
- 23 Top diaphragm case (valve on top)
- 24 Spring plate
- 25 Axial needle bearing with washer

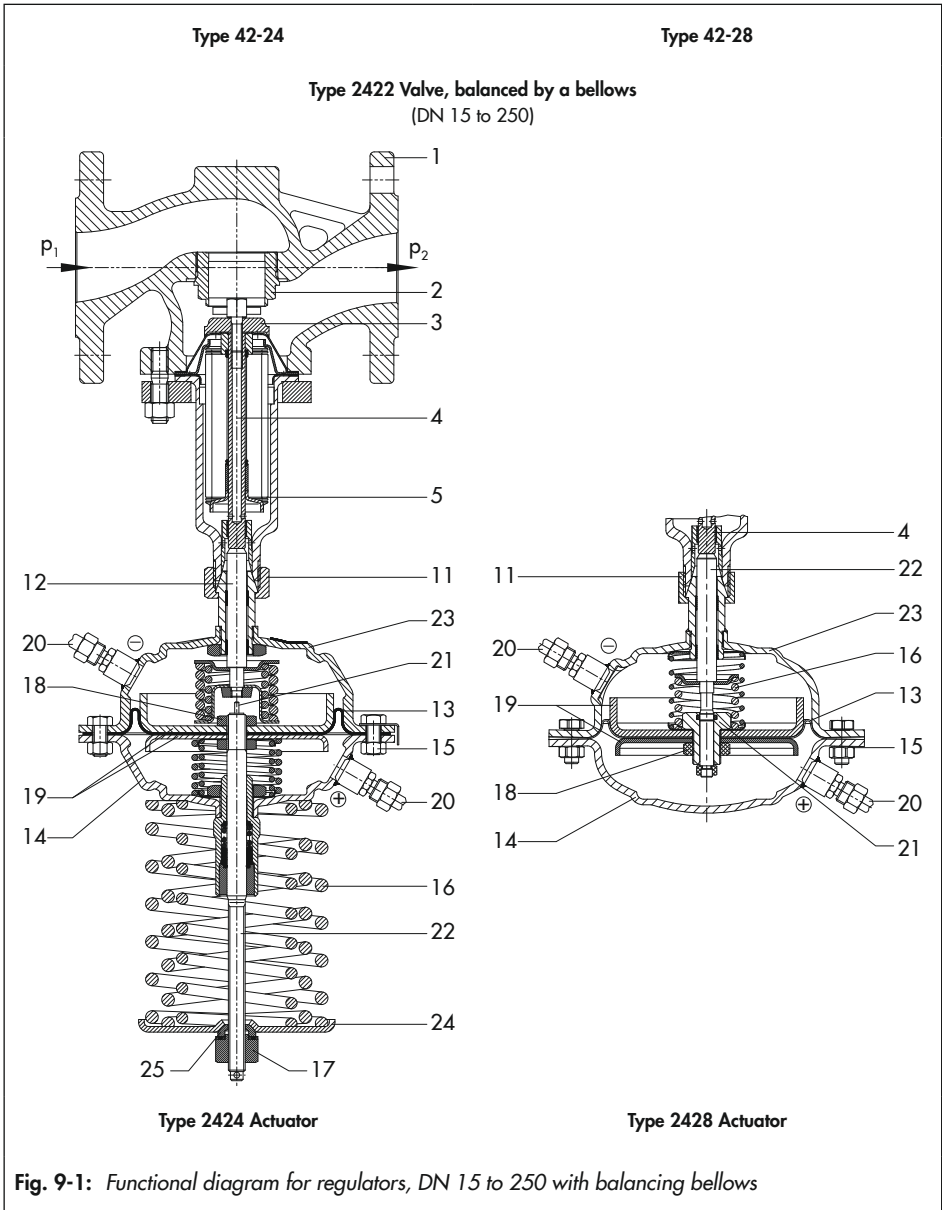

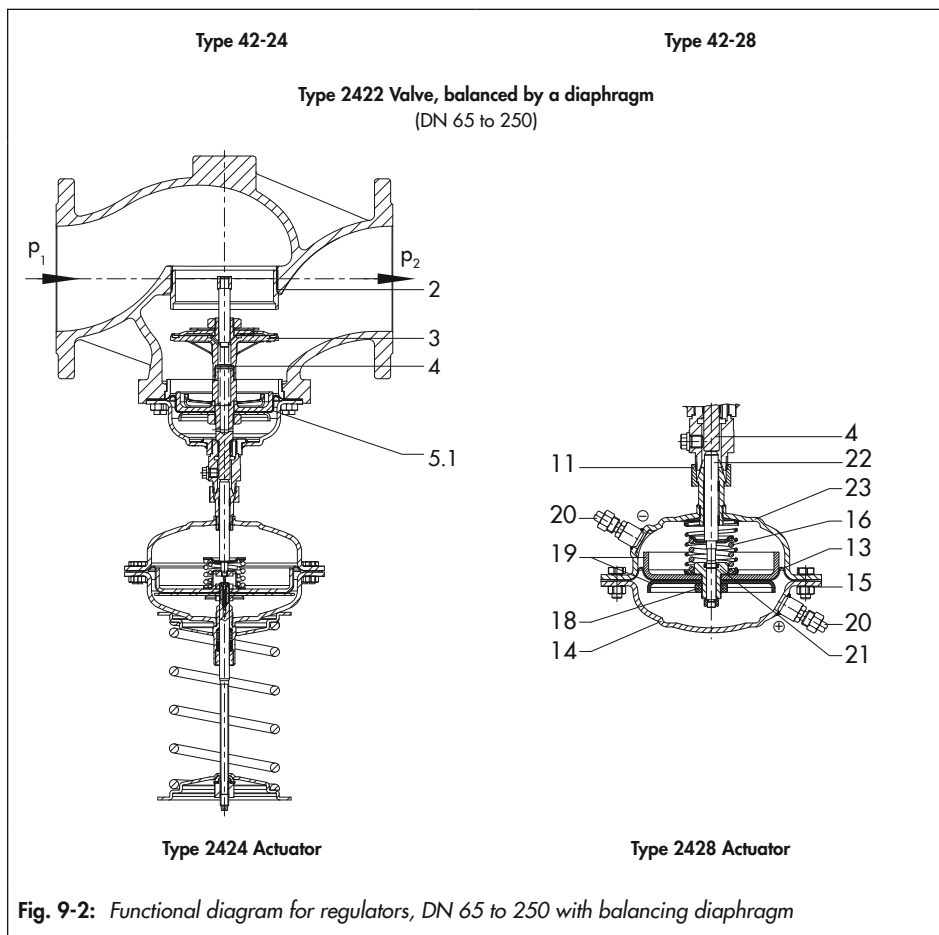

9.1 Preparing the valve for service work

1. Lay out the necessary material and tools to have them ready for the service work.
2. Put the regulator out of operation (see the 'Decommissioning' chapter).



Tip

We recommend removing the regulator from the pipeline before performing any service work (see the 'Removing the regulator from the pipeline' chapter).

The following service work can be performed after preparation is completed:

- Replace the actuator (see Chapter 9.4)
- Replace the seat and plug (see Chapter 9.5)
- Replace the actuator's operating diaphragm (see Chapter 9.6)

9.2 Installing the regulator after service work

- Put the regulator back into operation (see the 'Start-up' chapter). Make sure the requirements and conditions for start-up or putting the valve back into operation are met.

9.3 Service work

- Before performing any service work, preparations must be made to the regulator (see Chapter 9.1).
- After all service work is completed, check the regulator before putting it back into operation (see the 'Testing the regulator' chapter).

9.4 Replacing the actuator

- See Fig. 9-1 and Fig. 9-2

Removing the actuator

1. Put the regulator out of operation (see the 'Decommissioning' chapter).
2. Unscrew the control lines (20).
3. Unscrew the coupling nut (11) of the diaphragm actuator from the valve. Remove the actuator.

Mounting the actuator

1. Place the diaphragm actuator on the valve and fasten tight the coupling nut (11). Observe the specified tightening torques (see 'Tightening torques' in the Appendix).
2. Screw on the control lines (20). Observe the specified tightening torques (see 'Tightening torques' in the Appendix).
3. Put the regulator back into operation (see the 'Start-up' chapter).

9.5 Replacing the seat and plug

To replace seat and plug, contact SAMSON's After-sales Service.

Further information is available in the Appendix ('After-sales service').

9.6 Exchanging the operating diaphragm unit in the actuator



Tip

The associated order number is written on the actual operating diaphragm.

9.6.1 Type 2428 Actuator

→ See Fig. 9-1 and Fig. 9-2

Removing the operating diaphragm unit

1. Put the regulator out of operation (see the 'Decommissioning' chapter).
2. Unscrew the control lines (20).
3. Unscrew the coupling nut (11) of the diaphragm actuator from the valve. Remove the actuator.
4. Clamp the coupling nut (11) of the actuator into a suitable fixture.
5. Unscrew nuts and bolts (15) from the actuator. Remove the bottom diaphragm case (14).

6. Pull the operating diaphragm unit (consisting of items 13, 18, 19, 21 and 22) out of the top diaphragm case (23).

Installing the operating diaphragm unit

1. Insert the new operating diaphragm unit into the top diaphragm case (23).
2. Place on the bottom diaphragm case (14).
3. Insert nuts and bolts (15) and tighten gradually in a crisscross pattern. Observe the specified tightening torques (see 'Tightening torques' in the Appendix).
4. Place the diaphragm actuator on the valve and fasten tight the coupling nut (11). Observe the specified tightening torques (see 'Tightening torques' in the Appendix).
5. Screw on the control lines (20). Observe the specified tightening torques (see 'Tightening torques' in the Appendix).
6. Put the regulator back into operation (see the 'Start-up' chapter).

9.6.2 Type 2424 Actuator

→ See Fig. 9-1 and Fig. 9-2

Removing the operating diaphragm unit

1. Put the regulator out of operation (see the 'Decommissioning' chapter).
2. Completely relieve the tension from the set point springs (16) by turning the set point adjuster (17) counterclockwise (↺).

⚠ WARNING

Stored energy in the set point springs can cause components to move in an uncontrolled manner resulting in injury to hands or fingers.

3. Unscrew the control lines (20).
4. Unscrew the coupling nut (11) of the diaphragm actuator from the valve. Remove the actuator.
5. Clamp the coupling nut (11) of the actuator into a suitable fixture.
6. Unscrew the set point adjuster (17). Lift off the needle bearing with washer (25), spring plate (24) and set point springs (16).
7. Unscrew nuts and bolts (15) from the actuator. Lift off the bottom diaphragm case (14) including the operating diaphragm unit (consisting of items 13, 18, 19, 21 and 22).
8. Pull the operating diaphragm unit out of the bottom diaphragm case (14). Exchange the operating diaphragm unit.

Installing the operating diaphragm unit

1. Insert the new operating diaphragm unit into the bottom diaphragm case (14).
2. Place the bottom diaphragm case (14) with the new operating diaphragm unit onto the top diaphragm case (23).
3. Insert nuts and bolts (15) and tighten gradually in a crisscross pattern. Observe the specified tightening torques (see 'Tightening torques' in the Appendix).
4. Place on the set point springs (16), spring plate (24) and needle bearing with washer (25). Screw on the set point adjuster (17).
5. Place the diaphragm actuator on the valve and fasten tight the coupling nut (11). Observe the specified tightening torques (see 'Tightening torques' in the Appendix).
6. Screw on the control lines (20). Observe the specified tightening torques (see 'Tightening torques' in the Appendix).
7. Put the regulator back into operation (see the 'Start-up' chapter).

9.7 Ordering spare parts and operating supplies

Contact your nearest SAMSON subsidiary or SAMSON's After-sales Service for information on spare parts, lubricants and tools.

Spare parts

See Appendix for details on spare parts.

Lubricant

Contact SAMSON's After-sales Service for more information on lubricants.

Tools

Contact SAMSON's After-sales Service for more information on tools.

10 Decommissioning

The work described in this chapter is only to be performed by personnel appropriately qualified to carry out such tasks.

⚠ DANGER

Risk of bursting due to incorrect opening of pressurized equipment or components.

Regulators and pipelines are pressure equipment that may burst when handled incorrectly. Flying projectile fragments or the release of process medium under pressure can cause serious injury or even death.

Before working on the regulator:

- Depressurize all plant sections concerned and the regulator.
- Drain the process medium from all the plant sections concerned as well as the valve.

⚠ WARNING

Risk of burn injuries due to hot or cold components and pipeline.

Regulator components and the pipeline may become very hot or cold. Risk of burn injuries.

- Allow components and pipelines to cool down or warm up to the ambient temperature.
- Wear protective clothing and safety gloves.

⚠ WARNING

Risk of personal injury due to pressurized components and process medium being discharged.

Incorrect opening of pressure equipment or mounting parts may lead to the process medium escaping to the atmosphere.

- Do not loosen the control line while the valve is pressurized.
- Do not start up the regulator until all parts have been mounted.

⚠ WARNING

Risk of hearing loss or deafness due to loud noise.

Noise emission (e.g. cavitation) may occur during operation caused by the process medium and the operating conditions.

- Wear hearing protection when working near the valve. Follow the instructions given by the plant operator.

⚠ WARNING

Crush hazard arising from moving parts.

- Do not insert hands or fingers between the set point springs while the regulator is in operation.
- Do not insert hands or fingers between the pillars and set point springs while the regulator is in operation.
- Do not insert hands or fingers between the spring plate and crossbeam while the regulator is in operation.

Decommissioning

→ Before starting any work on the regulator, depressurize plant sections as well as the regulator.

WARNING

Risk of personal injury due to residual process medium in the regulator.

While working on the regulator, residual process medium can escape and, depending on its properties, may lead to personal injury, e.g. (chemical) burns.

→ Wear protective clothing, safety gloves and eye protection.

To decommission the regulator for service work or disassembly, proceed as follows:

1. Close the shut-off valve (1) on the upstream side of the regulator.
2. Close the shut-off valve (6) on the downstream side of the regulator.
3. Depressurize the plant.
4. Completely drain the pipelines and valve.
5. If necessary, allow the pipeline and regulator components to cool down or warm up to the ambient temperature.

11 Removal

The work described in this chapter is only to be performed by personnel appropriately qualified to carry out such tasks.

⚠ WARNING

Risk of burn injuries due to hot or cold components and pipeline.

Regulator components and the pipeline may become very hot or cold. Risk of burn injuries.

- *Allow components and pipelines to cool down or warm up to the ambient temperature.*
- *Wear protective clothing and safety gloves.*

⚠ WARNING

Risk of personal injury due to residual process medium in the regulator.

While working on the regulator, residual process medium can escape and, depending on its properties, may lead to personal injury, e.g. (chemical) burns.

- *Wear protective clothing, safety gloves and eye protection.*

Before removing the valve, make sure the following conditions are met:

- The regulator is put out of operation (see the 'Decommissioning' chapter).

11.1 Removing the regulator from the pipeline

1. Support the regulator to hold it in place when separated from the pipeline (see the 'Shipment and on-site transport' chapter).
2. Unbolt the flanged joint.
3. Remove the regulator from the pipeline (see the 'Shipment and on-site transport' chapter).

11.2 Removing the actuator from the valve

See the 'Servicing' chapter.

12 Repairs

If the regulator does not function properly according to how it was originally sized or does not function at all, it is defective and must be repaired or exchanged.

! NOTICE

Risk of regulator damage due to incorrect service or repair work.

→ Contact SAMSON's After-sales Service for service and repair work.

12.1 Returning devices to SAMSON

Defective devices can be returned to SAMSON for repair.

Proceed as follows to return devices:

1. Exceptions apply concerning some special device models
 - ▶ www.samsongroup.com > Service > After-sales Service.
2. Send an e-mail
 - ▶ retouren@samsongroup.com to register the return shipment including the following information:
 - Type
 - Material no.
 - Item numbers of accessories
 - Original order
 - Completed Declaration on Contamination, which can be downloaded from our website at
 - ▶ www.samsongroup.com > Service > After-sales Service.

After checking your registration, we will send you a return merchandise authorization (RMA).

3. Attach the RMA (together with the Declaration on Decontamination) to the outside of your shipment so that the documents are clearly visible.
4. Send the shipment to the address given on the RMA.

i Note

Further information on returned devices and how they are handled can be found at

▶ www.samsongroup.com > Service > After-sales Service.

13 Disposal



SAMSON is a producer registered in Europe, agency in charge

► <https://www.samsongroup.com/en/about-samson/environment-social-governance/material-compliance/waste-electrical-and-electronic-equipment-weee-and-its-safe-disposal/>.

WEEE reg. no.: DE 62194439

- Observe local, national and international refuse regulations.
- Do not dispose of components together with your other household waste.

Information on substances listed as substances of very high concern (SVHC) on the candidate list of the REACH regulation can be found in the document "Additional Information on Your Inquiry/Order", which is added to the order documents, if applicable. This document includes the SCIP number assigned to the devices concerned. This number can be entered into the database on the European Chemicals Agency (ECHA) website (► <https://www.echa.europa.eu/scip-database>) to find out more information on the SVHC contained in the device.

i Note

SAMSON can provide you with a recycling passport on request. Simply e-mail us at aftersaleservice@samsongroup.com giving details of your company address.

💡 Tip

On request, SAMSON can appoint a service provider to dismantle and recycle the product as part of a distributor take-back scheme.

14 Certificates

The EU declarations of conformity are included on the next pages:

- EU declaration of conformity in compliance with Pressure Equipment Directive 2014/68/EU on page 14-2.
- EU declaration of conformity in compliance with Machinery Directive 2006/42/EC for Type 42-24 and Type 42-28 Regulators on page 14-8.
- Declaration of incorporation in compliance with Machinery Directive 2006/42/EC for the Type 2422 Valve as well as Type 2424 and Type 2428 Actuators on page 14-9.

EU DECLARATION OF CONFORMITY
TRANSLATION



Module A

For the following products, SAMSON hereby declares under its sole responsibility:

Devices	Series	Type	Version
Self-operated Regulators	43	2432	DIN EN, body, CC499K and EN-GJS-400-18-LT, DN 50, PN 25, fluids G2, L2, L1 ¹⁾
	43	2436	DIN EN, body, CC499K and EN-GJS-400-18-LT, DN 50, PN 25, fluids G2, L2, L1 ¹⁾
	43	2437	DIN EN, body, CC499K and EN-GJS-400-18-LT, DN 50, PN 25, fluids G2, L2, L1 ¹⁾
	---	2111	DIN EN, body, EN-GJS-400-18-LT, DN 50, PN 25, fluids G2, L2, L1 ¹⁾ DIN EN, body, 1.0619 and 1.4408, DN 40-50, PN 40, fluids G2, L2, L1 ¹⁾ ANSI, body, A216 WCC and A351 CF8M, NPS 1½-2, Class 300, fluids G2, L2, L1 ¹⁾
Three-way valve	---	2119	DIN EN, body, EN-GJL-250 and 1.0619, DN 65-125, PN 16, fluids G2, L2, L1 ¹⁾
			DIN EN, body, 1.0619, DN 50-80, PN 25, fluids G2, L2, L1 ¹⁾
			DIN EN, body, 1.0619 and 1.4408, DN 40-50, PN 40, fluids G2, L2, L1 ¹⁾
			ANSI, body, A216 WCC and A351 CF8M, NPS 2½-4, Class 150, fluids G2, L2, L1 ¹⁾ ANSI, body, A216 WCC and A351 CF8M, NPS 1½, Class 300, fluids G2, L2, L1 ¹⁾
Control valve	---	3222	DIN EN, body, EN-GJS-400-18-LT, DN 50, PN 25, fluids G2, L2, L1 ¹⁾
			DIN EN, body, CC499K, DN 32-40, PN 25, all fluids
Three-way valve	---	3226	DIN EN, body, CC499K, DN 50, PN 25, fluids G2, L2 ²⁾
Three-way valve	---	3260	DIN EN, body, EN-GJL-250, DN 65-200, PN 16, fluids G2, L2 ²⁾
Globe valve Three-way valve	V2001	3531	DIN EN, body, EN-GJS-400-18-LT, DN 50-80, PN 25, fluids G2, L2, L1 ¹⁾
		3535	DIN EN, body, 1.0619 and 1.4408, DN 32-40, PN 25, all fluids ANSI, body, A216 WCC and A351 CF8M, NPS 1½-2, Class 150, all fluids
Control valve	---	3214	DIN EN, body, EN-GJL-250, DN 65-125, PN 16, fluids G2, L2, L1 ¹⁾
			DIN EN, body, EN-GJS-400-18-LT, DN 50-80, PN 25, fluids G2, L2, L1 ¹⁾
			ANSI, body, A126 B, NPS 3-4, Class 125, fluids G2, L2, L1 ¹⁾
			ANSI, body, A216 WCC and A351 CF8M, NPS 1½-2, Class 150, all fluids
Self-operated Regulators	42	2423	DIN EN, body, EN-GJL-250 and EN-GJS-400-18-LT, DN 65-125, PN 16, fluids G2, L2, L1 ¹⁾
			DIN EN, body, EN-GJS-418-LT, DN 50-80, PN 25, fluids G2, L2, L1 ¹⁾
			DIN EN, body, 1.0619 and 1.4408, DN 32-50, PN 16, all fluids
			DIN EN, body, 1.0619 and 1.4408, DN 32-40, PN 25, all fluids ANSI, body, A126 B, NPS 3-4, Class 125, fluids G2, L2, L1 ¹⁾
	42	2422	DIN EN, body, EN-GJL-250 and EN-GJS-400-18-LT, DN 65-125, PN 16, fluids G2, L2, L1 ¹⁾
			DIN EN, body, EN-GJS-400-18-LT, DN 50-80, PN 25, fluids G2, L2, L1 ¹⁾
			DIN EN, body, 1.0619, 1.4408 and 1.6220+QT, DN 32-50, PN 16, all fluids
			ANSI, body, A126 B, NPS 3-4, Class 125, fluids G2, L2, L1 ¹⁾ ANSI, body, A216 WCC, A351 CF8M and A352 LCC, NPS 1½-2, Class 150, all fluids
Strainers	1N/1NI	2601	DIN EN, body, CB752S, G 2 (DN50), PN25, fluids G2, L2 ²⁾
Strainers	2N/2NI	2602	DIN EN, body, EN-GJL-250, DN 200-250, PN 10, fluids G2, L2, L1 ¹⁾
			DIN EN, body, EN-GJL-250, DN 65-125, PN 16, fluids G2, L2, L1 ¹⁾
			DIN EN, body, EN-GJS-400-18-LT, DN 100-125, PN 16, fluids G2, L2, L1 ¹⁾
			DIN EN, body, EN-GJS-400-18-LT, DN 50-80, PN 25, fluids G2, L2, L1 ¹⁾ DIN EN, body, 1.4408, DN 32-50, PN 16, all fluids
Self-operated Regulators	---	2373/2375	ANSI, body, A995 4A and A995 5A, NPS 1½-2, Class 150, all fluids
		2440 (44-0B) 2441 (44-1B) 2440 (44-8B)	DIN EN, body, EN-GJS-400-18-LT, DN 50, PN 25, fluids G2, L2, L1 ¹⁾
	44	2442 (44-2) 2443 (44-3) 2444 (44-4) 2447 (44-7) 2449 (44-9)	DIN EN, body, EN-GJS-400-18-LT and CC499K, DN 50, PN 25, fluids G2, L2, L1 ¹⁾

Revision 01

EU DECLARATION OF CONFORMITY
TRANSLATION



Devices	Series	Type	Version
Self-operated Regulators	45	2451 (45-1)	DIN EN, body, EN-GJS-400-18-LT and CC499K, DN 50, PN 25, fluids G2, L2, L1 ¹⁾
		2452 (45-2)	
		2453 (45-3)	
		2454 (45-4)	
		2456 (45-6)	
	46	2465 (46-5)	DIN EN, body, EN-GJS-400-18-LT and CC499K, DN 50, PN 25, fluids G2, L2, L1 ¹⁾
		2466 (46-6)	
		2467 (46-7)	
		2469 (46-9)	
	47	2471 (47-1)	DIN EN, body, EN-GJS-400-18-LT and CC499K, DN 50, PN 25, fluids G2, L2, L1 ¹⁾
		2474 (47-4)	
		2475 (47-5)	
		2479 (47-9)	
	48	2488	DIN EN, body, EN-GJS-400-18-LT and CC499K, DN 50, PN 25, fluids G2, L2, L1 ¹⁾
		2489	
	40	2405	DIN EN, body, EN-GJS-400-18-LT, DN 50, PN 25, fluids G2, L2, L1 ¹⁾
			ANSI, body, A216 WCC and A351 CF8M, NPS 1½-2, Class 150, all fluids
		2406	DIN EN, body, EN-GJL-250, DN 65-125, PN 16, fluids G2, L2, L1 ¹⁾
			DIN EN, body, EN-GJS-400-18-LT, DN 50, PN 25, fluids G2, L2, L1 ¹⁾
			ANSI, body, A126 B, NPS 3-4, Class 125, fluids G2, L2, L1 ¹⁾
	41	2412 2417	ANSI, body, A216 WCC and A351 CF8M, NPS 1½-2, Class 150, all fluids
			DIN EN, body, EN-GJL-250, DN 65-100, PN 16, fluids G2, L2, L1 ¹⁾
	42	2421 RS	DIN EN, body, EN-GJS-400-18-LT, DN 50-80, PN 25, fluids G2, L2, L1 ¹⁾
			ANSI, body, A126 B, NPS 3-4, Class 125, fluids G2, L2, L1 ¹⁾
	---	2331	DIN EN, body, 1.0619, 1.4408, 1.4571 and 1.4401/1.4404, DN 32-50, PN 16, all fluids
			DIN EN, body, 1.0619, 1.4408, 1.4571 and 1.4401/1.4404, DN 32-40, PN 25, all fluids
	---	2337	ANSI, body, A216 WCC, A351 CF8M and A182 F316/A182 F316L, NPS 1½-2, Class 150, all fluids
			DIN EN, body, EN-GJL-250, DN 65-200, PN 16, fluids G2, L2 ²⁾
---	2333 2335	DIN EN, body, EN-GJS-400-18-LT, DN 65-150, PN 16, fluids G2, L2 ²⁾	
		DIN EN, body, EN-GJS-400-18-LT, DN 65-125, PN 25, fluids G2, L2 ²⁾	
---	2334	DIN EN, body, 1.0619, DN 65-200, PN 16, fluids G2, L2 ²⁾	
		DIN EN, body, 1.0619, DN 65-100, PN 40, fluids G2, L2 ²⁾	
---	2404-1	DIN EN, body, 1.0619, DN 250, PN 25, fluids L1 ¹⁾	
		DIN EN, body, EN-GJL-250, DN 65-125, PN 16, fluids G2, L2, L1 ¹⁾	
---	2404-2	DIN EN, body, EN-GJS-400-18-LT, DN 65-80, PN 25, fluids G2, L2, L1 ¹⁾	
		ANSI, body, A126 B, NPS 3-4, Class 125, fluids G2, L2, L1 ¹⁾	

¹⁾ Cases according to Article 4(1)(c.i), second indent
Liquids according to Article 4(1)(c.ii)

²⁾ Cases according to Article 4(1)(c.i), second indent
Liquids according to Article 4(1)(c.ii), second indent

Revision 01

Classification: Public - SAMSON AKTIENGESELLSCHAFT · Weismuellerstrasse 3 · 60314 Frankfurt am Main, Germany

Page 2 of 3

EU DECLARATION OF CONFORMITY
TRANSLATION



That the products mentioned above comply with the requirements of the following standards:

Directive of the European Parliament and of the Council on the harmonization of the laws of the Member States relating to the making available on the market of pressure equipment	2014/68/EU	of 15. May 2014
Applied conformity assessment procedure for fluids according to Article 4(1)	Module A	

Technical standards applied: DIN EN 12516-2, DIN EN 12516-3, ASME B16.34

Manufacturer: SAMSON AG, Weismüllerstraße 3, 60314 Frankfurt am Main, Germany

Frankfurt am Main, 05. June 2024

ppc. Norbert Tollas
Senior Vice President
Global Operations

i.V. Peter Scheermesser
Director
Product Maintenance & Engineered Products

Revision 01

Classification: Public · SAMSON AKTIENGESELLSCHAFT · Weismuellerstrasse 3 · 60314 Frankfurt am Main, Germany Page 3 of 3

EU DECLARATION OF CONFORMITY
TRANSLATION



Module H / N° CE-0062-PED-H-SAM 001-22-DEU-rev-A

For the following products, SAMSON hereby declares under its sole responsibility:

Devices	Series	Type	Version
Three-way valve	---	2119	DIN EN, body, EN-GJL-250 and 1.0619, DN 150, PN 16, fluids G2, L2, L1 ¹⁾
			DIN EN, body, 1.0619, DN 100-150, PN 25, fluids G2, L2, L1 ¹⁾
			DIN EN, body, 1.0619 and 1.4408, DN 65-150, PN 40, fluids G2, L2, L1 ¹⁾
			ANSI, body, A216 WCC and A351 CF8M, NPS 6, Class 150, fluids G2, L2, L1 ¹⁾
			ANSI, body, A216 WCC and A351 CF8M, NPS 2-6, Class 300, fluids G2, L2, L1 ¹⁾
Self-operated Regulators	---	3222	DIN EN, body, CC499K, DN 50, PN 25, all fluids
Three-way valve	---	3260	DIN EN, body, EN-GJL-250, DN 250-300, PN 16, fluids G2, L2 ¹⁾
Globe valve Three-way valve	V2001	3531	DIN EN, body, 1.0619 and 1.4408, DN 50-80, PN 25, all fluids
		3535	ANSI, body, A216 WCC and A351 CF8M, NPS 2½-3, Class 150, all fluids
Control valve	---	3214	DIN EN, body, EN-GJL-250, DN 150-400, PN 16, fluids G2, L2, L1 ¹⁾
			DIN EN, body, EN-GJS-400-18-LT, DN 100-150, PN 25, fluids G2, L2, L1 ¹⁾
			DIN EN, body, 1.0619, DN 32-400, PN 40, all fluids
			ANSI, body, A126 B, NPS 6-10, Class 125, fluids G2, L2, L1 ¹⁾
			ANSI, body, A216 WCC, NPS 2½-10, Class 150, all fluids
Self-operated Regulators	42	2423	ANSI, body, A216 WCC, NPS 1½-10, Class 300, all fluids
			DIN EN, body, EN-GJL-250, DN 150-250, PN 16, fluids G2, L2, L1 ¹⁾
			DIN EN, body, EN-GJS-400-18-LT, DN 150, PN 16, fluids G2, L2, L1 ¹⁾
			DIN EN, body, EN-GJS-400-18-LT, DN 100-150, PN 25, fluids G2, L2, L1 ¹⁾
			DIN EN, body, 1.0619 and 1.4408, DN 65-250, PN 16, all fluids
			DIN EN, body, 1.0619 and 1.4408, DN 50-250, PN 25, all fluids
			DIN EN, body, 1.0619 and 1.4408, DN 32-250, PN 40, all fluids
			ANSI, body, A126 B, NPS 6-10, Class 125, fluids G2, L2, L1 ¹⁾
			ANSI, body, A216 WCC and A351 CF8M, NPS 2½-10, Class 150, all fluids
			ANSI, body, A216 WCC and A351 CF8M, NPS 1½-10, Class 300, all fluids
			DIN EN, body, EN-GJL-250, DN 150-400, PN 16, fluids G2, L2, L1 ¹⁾
			DIN EN, body, EN-GJS-400-18-LT, DN 100-150, PN 25, fluids G2, L2, L1 ¹⁾
	DIN EN, body, 1.0619 and 1.4408, DN 65-400, PN 16, all fluids		
	DIN EN, body, 1.0619 and 1.4408, DN 200-400, PN 25, all fluids		
	DIN EN, body, 1.0619 and 1.4408, DN 32-400, PN 40, all fluids		
	DIN EN, body, 1.0460, DN 40-50, PN 40, all Fluids		
	DIN EN, body, 1.6220+QT, DN 65-250, PN 16, all fluids		
	DIN EN, body, 1.6220+QT, DN 200-250, PN 25, all fluids		
	DIN EN, body, 1.6220+QT, DN 32-250, PN 40, all fluids		
	ANSI, body, A126 B, NPS 6-16, Class 125, fluids G2, L2, L1 ¹⁾		
	ANSI, body, A216 WCC and A351CF8M, NPS 2½-16, Class 150, all fluids		
	ANSI, body, A216 WCC and A351CF8M, NPS 1½-16, Class 300, all fluids		
	ANSI, body, A105, NPS 1½-2, Class 300, all fluids		
	ANSI, body, A352 LCC, NPS 2½-10, Class 150, all fluids		
	ANSI, body, A352 LCC, NPS 1½-10, Class 300, all fluids		
	DIN EN, body, 1.0619 and 1.4408, DN 65-150, PN 16, all fluids		
	DIN EN, body, 1.0619 and 1.4408, DN 50-150, PN 25, all fluids		
DIN EN, body, 1.0619 and 1.4408, DN 32-150, PN 40, all fluids			
DIN EN, body, 1.4571 and 1.4401/1.4404, DN 50, PN 25, all fluids			
DIN EN, body, 1.4571 and 1.4401/1.4404, DN 32-50, PN 40, all fluids			
ANSI, body, A216 WCC and A351 CF8M, NPS 2½-6, Class 150, all fluids			
ANSI, body, A216 WCC and A351 CF8M, NPS 1½-6, Class 300, all fluids			

Revision 01

Classification: Public · SAMSON AKTIENGESELLSCHAFT · Weismuellerstrasse 3 · 60314 Frankfurt am Main, Germany

Page 1 of 3

EU DECLARATION OF CONFORMITY
TRANSLATION



Devices	Series	Type	Version	
Self-operated Regulators	40	2405	DIN EN, body, 1.0619, 1.4571, 1.4404, 1.4408, 1.0460, DN 32-50, PN40, all fluids	
			ANSI, body, A105, A182 F316L, A351 CF8M, A216 WCC, NPS 1½-2, Class 300, all fluids	
		2406	DIN EN, body, EN-GJL-250, DN 150, PN 16, fluids G2, L2, L1 ¹⁾	
			DIN EN, body, 1.0619 and 1.4408, DN 32-150, PN 40, all fluids	
			DIN EN, body, 1.0460 and 1.4404, DN 32-50, PN 40, all fluids	
			ANSI, body, A128 B, NPS 6, Class 125, fluids G2, L2, L1 ¹⁾	
			ANSI, body, A218 WCC and A351 CF8M, NPS 2½-6, Class 150, all fluids	
			ANSI, body, A216 WCC and A351 CF8M, NPS 1½-6, Class 300, all fluids	
		41	2412 2417	ANSI, body, A105 and A182 F316L, NPS 1½-2, Class 300, all fluids
				DIN EN, body, EN-GJS-400-18-LT, DN 100, PN25, fluids G2, L2, L1 ¹⁾
				DIN EN, body, 1.0619 and 1.4408, DN 32-100, PN 40, all fluids
				DIN EN, body, 1.0460, 1.4571 and 1.4404, DN 32-80, PN 40, all fluids
	ANSI, body, A216 WCC and A351 CF8M, NPS 2½-4, Class 150, all fluids			
	ANSI, body, A216 WCC and A351 CF8M, NPS 1¼-4, Class 300, all fluids			
	---		2404-1	ANSI, body, A105 and A182 F316L, NPS 1½-3, Class 300, all fluids
				DIN EN, body, EN-GJL-250, DN 150, PN16, fluids G2, L2, L1 ¹⁾
				DIN EN, body, 1.0619 and 1.4408, DN 32-150, PN 40, all fluids
				ANSI, body, A128 B, NPS 6, Class 125, fluids G2, L2, L1 ¹⁾
				ANSI, body, A218 WCC and A351 CF8M, NPS 2½-6, Class 150, all fluids
				ANSI, body, A216 WCC und A351 CF8M, NPS 1½-6, Class 300, all fluids
	---	2404-2	DIN EN, body, EN-GJL-250, DN 150-400, PN 16, fluids G2, L2, L1 ¹⁾	
			DIN EN, body, 1.0619 und 1.4408, DN 65-400, PN 16, all fluids	
			DIN EN, body, 1.0619 und 1.4408, DN 65-400, PN 40, all fluids	
			ANSI, body, A126 B, NPS 6-16, Class 125, fluids G2, L2, L1 ¹⁾	
			ANSI, body, A216 WCC und A351 CF8M, NPS 2½-16, Class 150, all fluids	
			ANSI, body, A216 WCC und A351 CF8M, NPS 2½-10, Class 300, all fluids	
		---	2331	DIN EN, body, EN-GJL-250, DN 250, PN 16, fluids G2, L2 ²⁾
				DIN EN, body, 1.0619, DN 250, PN 16, fluids G2, L2 ²⁾
				DIN EN, body, 1.0619, DN 200-250, PN 25, fluids G2, L2 ²⁾
				DIN EN, body, 1.0619, DN 125-250, PN 40, fluids G2, L2 ²⁾
				DIN EN, body, EN-GJL-250, DN 150-400, PN 16, fluids G2, L2, L1 ¹⁾
				DIN EN, body, EN-GJS-400-18-LT, DN 100-150, PN 25, fluids G2, L2, L1 ¹⁾
	---	2333 2335	DIN EN, body, 1.0619 and 1.4408, DN 65-400, PN 16, all fluids	
			DIN EN, body, 1.0619 and 1.4408, DN 200-400, PN 25, all fluids	
			DIN EN, body, 1.0619 and 1.4408, DN 65-400, PN 40, all fluids	
			ANSI, body, A126 B, NPS 6-16, Class 125, fluids G2, L2, L1 ¹⁾	
ANSI, body, A216 WCC and A351 CF8M, NPS 2½-16, Class 150, all fluids				
ANSI, body, A216 WCC and A351 CF8M, NPS 2½-16, Class 300, all fluids				
---		2334	DIN EN, body, EN-GJL-250, DN 150-400, PN 16, fluids G2, L2, L1 ¹⁾	
			DIN EN, body, EN-GJS-400-18-LT, DN 150, PN 16, fluids G2, L2, L1 ¹⁾	
			DIN EN, body, EN-GJS-400-18-LT, DN 100-150, PN 25, fluids G2, L2, L1 ¹⁾	
			DIN EN, body, 1.0619 and 1.4408, DN 65-400, PN 16, all fluids	
			DIN EN, body, 1.0619 and 1.4408, DN 200-400, PN 25, all fluids	
			DIN EN, body, 1.0619 and 1.4408, DN 65-400, PN 40, all fluids	
---	2373 2375	ANSI, body, A126 B, NPS 6-16, Class 125, fluids G2, L2, L1 ¹⁾		
		ANSI, body, A216 WCC and A351 CF8M, NPS 2½-16, Class 150, all fluids		
		ANSI, body, A216 WCC and A351 CF8M, NPS 2½-16, Class 300, all fluids		
		DIN EN, body, EN-GJL-250, DN 150-400, PN 16, fluids G2, L2, L1 ¹⁾		
		DIN EN, body, EN-GJS-400-18-LT, DN 100-150, PN 25, fluids G2, L2, L1 ¹⁾		
		DIN EN, body, 1.0619 and 1.4408, DN 65-400, PN 16, all fluids		
Strainers	2N/2NI	2602	DIN EN, body, 1.4469 and 1.4470, DN 32-50, PN 40, all fluids	
			ANSI, body, A995 5A and A995 4A, NPS 1½-2, Class 300, all fluids	
			DIN EN, body, EN-GJL-250, DN 150-250, PN 16, fluids G2, L2, L1 ¹⁾	
			DIN EN, body, EN-GJS-400-18-LT, DN 150, PN 16, fluids G2, L2, L1 ¹⁾	
			DIN EN, body, EN-GJS-400-18-LT, DN 100-150, PN 25, fluids G2, L2, L1 ¹⁾	
			DIN EN, body, 1.0619, DN 100-250, PN 16, all fluids	

Revision 01

EU DECLARATION OF CONFORMITY
TRANSLATION



Devices	Series	Type	Version
Strainers	2N/2NI	2602	DIN EN, body, 1.0619, DN 200-250, PN 25, all fluids
			DIN EN, body, 1.0619, DN 32-250, PN 40, all fluids
			DIN EN, body, 1.4408, DN 65-100, PN 16, all fluids
			DIN EN, body, 1.4408, DN 32-100, PN 40, all fluids

¹⁾Gases according to Article 4(1)(c.i), second indent
Liquids according to Article 4(1)(c.ii)

That the products mentioned above comply with the requirements of the following standards:

Directive of the European Parliament and of the Council on the harmonization of the laws of the Member States relating to the making available on the market of pressure equipment	2014/68/EU	of 15. May 2014
Applied conformity assessment procedure for fluids according to Article 4(1)	Module H	by Bureau Veritas 0062

The manufacturer's quality management system is monitored by the following notified body:
Bureau Veritas Services SAS, 4 place des Saisons, 92400 Courbevoie, France
Technical standards applied: DIN EN 12516-2, DIN EN 12516-3, ASME B16.34

Manufacturer: SAMSON AG, Weismuellerstrasse 3, 60314 Frankfurt am Main, Germany

Frankfurt am Main, 05. June 2024

ppc. G. Tollas

ppa. Norbert Tollas
Senior Vice President
Global Operations

i. V. P. Scheermesser

i.V. Peter Scheermesser
Director
Product Maintenance & Engineered Products

Revision 01

EU DECLARATION OF CONFORMITY
TRANSLATION



Declaration of Conformity of Final Machinery

in accordance with Annex II, section 1.A. of the Directive 2006/42/EC

For the following products:

Type 42-24 Differential Pressure Regulator consisting of Type 2422 Valve and Type 2424 Actuator as well as Type 42-28 Differential Pressure Regulator consisting of Type 2422 Valve and Type 2428 Actuator

We hereby declare that the machinery mentioned above complies with all applicable requirements stipulated in Machinery Directive 2006/42/EC.

For product descriptions of the valve and actuator, refer to:

- Type 42-24 Differential Pressure Regulator: Mounting and Operating Instructions EB 3003
- Type 42-28 Differential Pressure Regulator: Mounting and Operating Instructions EB 3003

Referenced technical standards and/or specifications:

- VCI, VDMA, VGB: "Leitfaden Maschinenrichtlinie (2006/42/EG) – Bedeutung für Armaturen, Mai 2018" [German only]
- VCI, VDMA, VGB: "Zusatzdokument zum Leitfaden Maschinenrichtlinie (2006/42/EG) – Bedeutung für Armaturen vom Mai 2018" [German only], based on DIN EN ISO 12100:2011-03

Comment:

Information on residual risks of the machinery can be found in the mounting and operating instructions of the valve and actuator as well as in the referenced documents listed in the mounting and operating instructions.

Persons authorized to compile the technical file:

SAMSON AG, Weismüllerstraße 3, 60314 Frankfurt am Main, Germany
Frankfurt am Main, 22 July 2020.

Thorsten Muth
Senior Director
Sales and After-sales

i.v. P. Scheermesser
Peter Scheermesser
Director
Product Life Cycle Management and ETO
Development for Valves and Actuators

Revision no. 00

DECLARATION OF INCORPORATION
TRANSLATION



Declaration of Incorporation in Compliance with Machinery Directive 2006/42/EC

For the following product: **Type 2422 Valve**

We certify that the Type 2422 Valve is partly completed machinery as defined in the Machinery Directive 2006/42/EC and that the safety requirements stipulated in Annex I, 1.1.2, 1.1.3, 1.1.5, 1.3.2, 1.3.4 and 1.3.7 are observed. The relevant technical documentation described in Annex VII, part B has been compiled.

Products we supply must not be put into service until the final machinery into which it is to be incorporated has been declared in conformity with the provisions of the Machinery Directive 2006/42/EC.

Operators are obliged to install the products observing the accepted industry codes and practices (good engineering practice) as well as the mounting and operating instructions. Operators must take appropriate precautions to prevent hazards that could be caused by the process medium and operating pressure in the valve as well as by the signal pressure and moving parts.

The permissible limits of application and mounting instructions for the products are specified in the associated mounting and operating instructions; the documents are available in electronic form on the Internet at www.samsongroup.com.

For product descriptions refer to:

- Types 1, 4 and 4u Temperature Regulators: Mounting and Operating Instructions EB 2111/2121/2123
- Type 2404-2 Excess Pressure Valve with pilot valve: Mounting and Operating Instructions EB 2540
- Type 2422/2424 Pressure Reducing Valve: Mounting and Operating Instructions EB 2547
- Type 2422/2425 Excess Pressure Valve: Mounting and Operating Instructions EB 2549
- Type 2333 Pressure Reducing Valve with pilot valve: Mounting and Operating Instructions EB 2552-1
- Type 2335 Excess Pressure Valve with pilot valve: Mounting and Operating Instructions EB 2552-2
- Type 2334 Universal Regulator with pilot valve: Mounting and Operating Instructions EB 3210
- Type 42-20, Type 42-25 Differential Pressure Regulators: Mounting and Operating Instructions EB 3007
- Type 42-24, Type 42-28 Differential Pressure Regulators: Mounting and Operating Instructions EB 3003
- Safety Temperature Limiters (STL) with Type 2212 Safety Thermostat: Mounting and Operating Instructions EB 2046
- Type 2213 Safety Temperature Monitor (STM): Mounting and Operating Instructions EB 2043

Referenced technical standards and/or specifications:

- VCI, VDMA, VGB: "Leitfaden Maschinenrichtlinie (2006/42/EG) – Bedeutung für Armaturen, Mai 2018" [German only]
- VCI, VDMA, VGB: "Zusatzdokument zum Leitfaden Maschinenrichtlinie (2006/42/EG) – Bedeutung für Armaturen vom Mai 2018" [German only], based on DIN EN ISO 12100:2011-03

Comments:

- See mounting and operating instructions for residual hazards.
- Also observe the referenced documents listed in the mounting and operating instructions.

Persons authorized to compile the technical file:

SAMSON AG, Weismüllerstraße 3, 60314 Frankfurt am Main, Germany
Frankfurt am Main, 10 November 2021

Stephan Giesen
Director
Product Management

Peter Scheermesser
Director
Product Life Cycle Management and ETO
Development for Valves and Actuators

Revision no. 00

DECLARATION OF INCORPORATION
TRANSLATION



Declaration of Incorporation in Compliance with Machinery Directive 2006/42/EC

For the following product:
Type 2424 Actuators

We certify that the Type 2424 Actuator is partly completed machine as defined in the Machinery Directive 2006/42/EC and that the safety requirements stipulated in Annex I, 1.1.2, 1.1.3, 1.1.5, 1.3.2, 1.3.4 and 1.3.7 are observed. The relevant technical documentation described in Annex VII, part B has been compiled.

Products we supply must not be put into service until the final machinery into which it is to be incorporated has been declared in conformity with the provisions of the Machinery Directive 2006/42/EC.

Operators are obliged to install the products observing the accepted industry codes and practices (good engineering practice) as well as the mounting and operating instructions. Operators must take appropriate precautions to prevent hazards that could be caused by the process medium and operating pressure in the valve as well as by the signal pressure and moving parts.

The permissible limits of application and mounting instructions for the products are specified in the associated data sheets as well as the mounting and operating instructions; the documents are available in electronic form on the Internet at www.samsongroup.com.

For product descriptions refer to:

- Type 42-24 Differential Pressure Regulator: Mounting and Operating Instructions EB 3003
- Type 2422/2424 Pressure Reducing Valve: Mounting and Operating Instructions EB 2549
- Type 42-34 Differential Pressure Limiter with Flow Limitation: Mounting and Operating Instructions EB 3013

Referenced technical standards and/or specifications:

- VCI, VDMA, VGB: "Leitfaden Maschinenrichtlinie (2006/42/EG) – Bedeutung für Armaturen, Mai 2018" [German only]
- VCI, VDMA, VGB: "Zusatzdokument zum Leitfaden Maschinenrichtlinie (2006/42/EG) – Bedeutung für Armaturen vom Mai 2018" [German only], based on DIN EN ISO 12100:2011-03

Comments:

- See mounting and operating instructions for residual hazards.
- Also observe the referenced documents listed in the mounting and operating instructions.

Persons authorized to compile the technical file:

SAMSON AG, Weismüllerstraße 3, 60314 Frankfurt am Main, Germany
Frankfurt am Main, 20 September 2021

Stephan Giesen
Director
Product Management

Peter Scheermesser
Director
Product Life Cycle Management and ETO Development for
Valves and Actuators

Revision no. 00

DECLARATION OF INCORPORATION
TRANSLATION



Declaration of Incorporation in Compliance with Machinery Directive 2006/42/EC

For the following product:
Type 2428 Actuators

We certify that the Type 2428 Actuator is partly completed machine as defined in the Machinery Directive 2006/42/EC and that the safety requirements stipulated in Annex I, 1.1.2, 1.1.3, 1.1.5, 1.3.2, 1.3.4 and 1.3.7 are observed. The relevant technical documentation described in Annex VII, part B has been compiled.

Products we supply must not be put into service until the final machinery into which it is to be incorporated has been declared in conformity with the provisions of the Machinery Directive 2006/42/EC.

Operators are obliged to install the products observing the accepted industry codes and practices (good engineering practice) as well as the mounting and operating instructions. Operators must take appropriate precautions to prevent hazards that could be caused by the process medium and operating pressure in the valve as well as by the signal pressure and moving parts.

The permissible limits of application and mounting instructions for the products are specified in the associated data sheets as well as the mounting and operating instructions; the documents are available in electronic form on the Internet at www.samsongroup.com.

For product descriptions refer to:

- Type 42-28 Differential Pressure Regulator: Mounting and Operating Instructions EB 3003
- Type 42-38 Differential Pressure Limiter with Flow Limitation: Mounting and Operating Instructions EB 3013

Referenced technical standards and/or specifications:

- VCI, VDMA, VGB: "Leitfaden Maschinenrichtlinie (2006/42/EG) – Bedeutung für Armaturen, Mai 2018" [German only]
- VCI, VDMA, VGB: "Zusatzdokument zum Leitfaden Maschinenrichtlinie (2006/42/EG) – Bedeutung für Armaturen vom Mai 2018" [German only], based on DIN EN ISO 12100:2011-03

Comments:

- See mounting and operating instructions for residual hazards.
- Also observe the referenced documents listed in the mounting and operating instructions.

Persons authorized to compile the technical file:

SAMSON AG, Weismüllerstraße 3, 60314 Frankfurt am Main, Germany
Frankfurt am Main, 7 February 2022



Stephan Giesen
Director
Product Management



Peter Scheermesser
Director
Product Life Cycle Management and ETO
Development for Valves and Actuators

Revision no. 00

Classification: Public · SAMSON AKTIENGESELLSCHAFT · Weismüllerstraße 3 · 60314 Frankfurt, Germany

Page 1 of 1

15 Appendix

15.1 Tightening torques

Table 15-1: *Tightening torque*

Component	Width across flats	Nominal size or actuator area	Tightening torque in Nm
Coupling nuts (11)	A/F 36	All	120
Nuts and bolts (15)	–	40 to 640 cm ²	25
Nut (18)	A/F 12	40 to 640 cm ²	40
Control line connection (20)	–	40 to 640 cm ²	22

15.2 Lubricants

SAMSON's After-sales Service can support you concerning lubricants and sealants approved by SAMSON.

15.3 Tools

SAMSON's After-sales Service can support you concerning tools approved by SAMSON.

15.1 Accessories

Control line kits, needle valves, condensation chambers and compression-type screw fittings can be supplied as required. These accessories are listed in ► T 3095.

15.4 Spare parts

Legend for Fig. 15-1 and Fig. 15-2

1	Body	97	Flange
2	Bottom section	109	Nameplate
4	Seat	500	Bellows
5	Plug	502	Balancing screw
12	Washer	506	Connecting nipple
13	Bolt	507	Guide cap
14	Nut	525	Compression spring
18	Guide bushing	558	Washer
19	Guide tube	596	Retaining washer
36	Nipple		

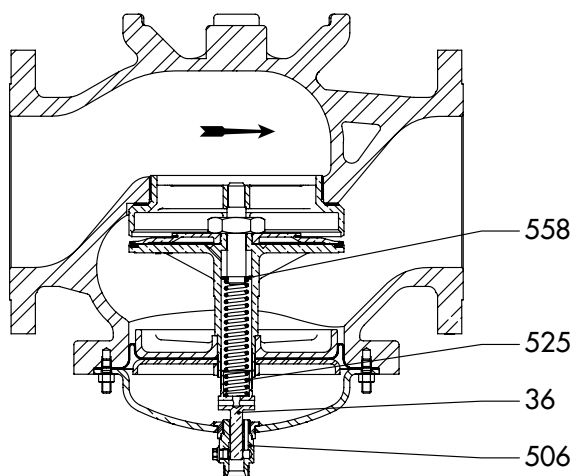

Fig. 15-1: Type 2422 Valve, DN 65 to 250 · Balanced by a diaphragm

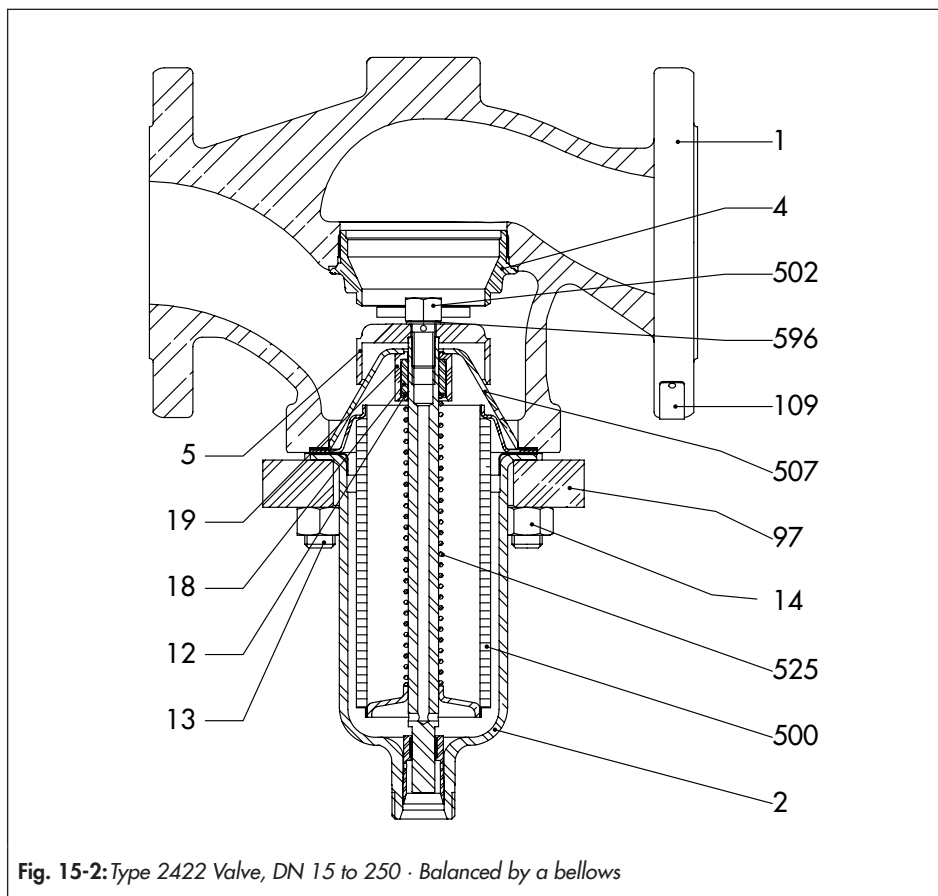
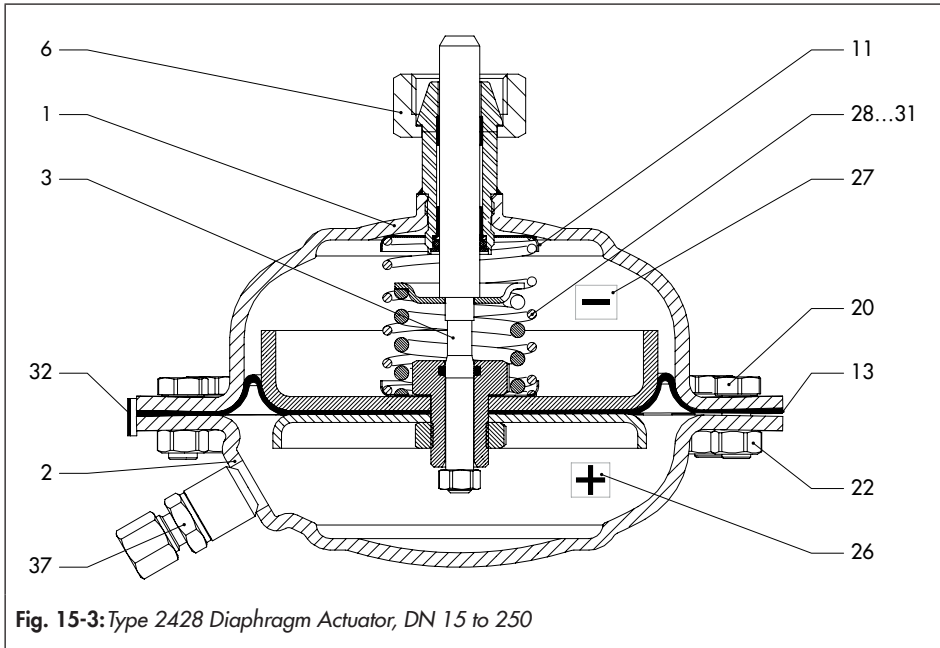

Fig. 15-2: Type 2422 Valve, DN 15 to 250 · Balanced by a bellows

Appendix

Legend for Fig. 15-3

1	Diaphragm case assembly	20	Bolt
2	Diaphragm case assembly	22	Nut
3	Diaphragm stem with excess pressure limiter and diaphragm	26	Adhesive label +
6	Coupling nut	27	Adhesive label -
11	Spring plate	28...31	Compression spring
13	Diaphragm	32	Nameplate
		37	Screw joint with restriction



Legend for Fig. 15-4

1	Diaphragm case assembly	20	Adhesive label +
2	Diaphragm case assembly	21	Adhesive label -
4	Nipple	22	Nameplate
5	Guide nipple	25	Nut of set point adjuster
7	Diaphragm stem with excess pressure limiter and diaphragm	27...29	Set point springs
8	Force limiter	30	Compression spring
11	Coupling nut	36	Spring plate
17	Bolt	46	Axial needle bearing
18	Nut	49	Cap
		51	Washer

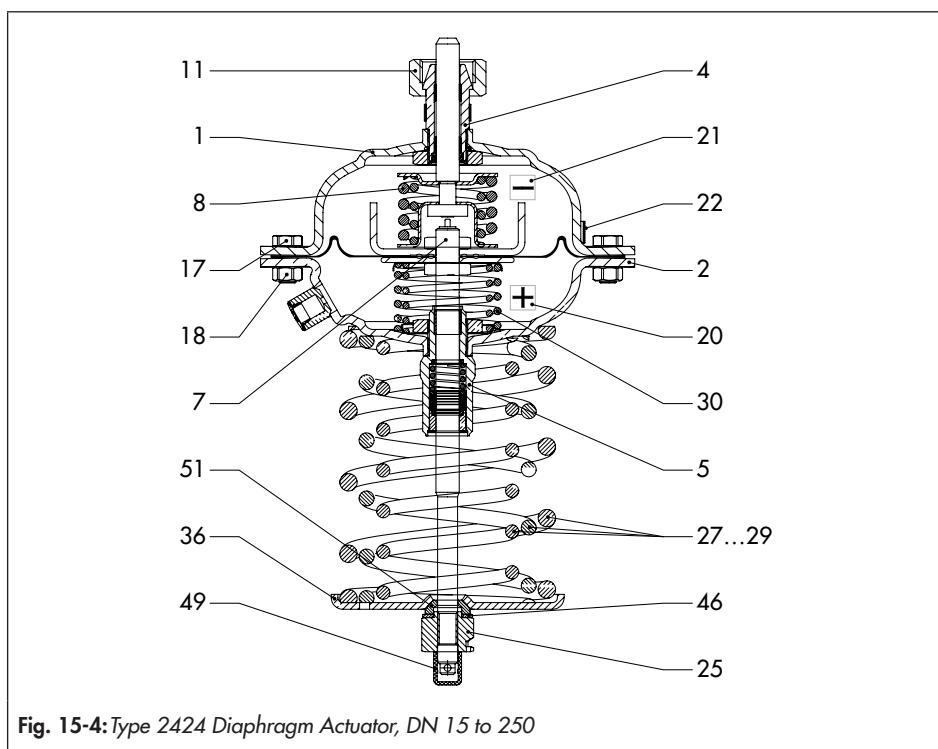

Fig. 15-4: Type 2424 Diaphragm Actuator, DN 15 to 250

Appendix

Legend for Fig. 15-5

1	Diaphragm stem
2	Diaphragm plate
3	Diaphragm

4	Washer
5	Spring plate
6	Nut

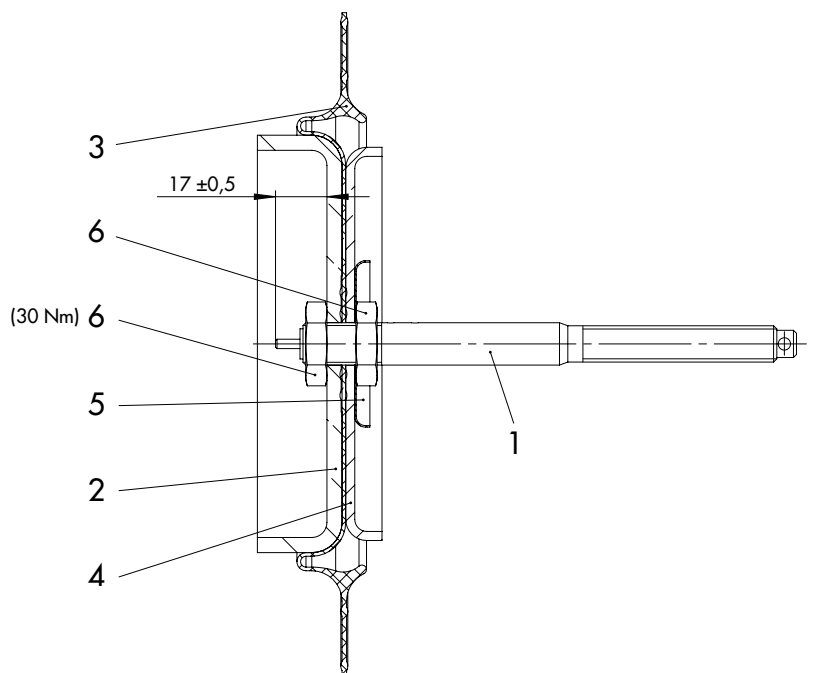

Fig. 15-5: Diaphragm stem, excess pressure limiter and diaphragm · Type 2424 (DN 15 to 250)

15.5 After-sales service

Contact SAMSON's After-sales Service for support concerning service or repair work or when malfunctions or defects arise.

E-mail contact

You can reach our after-sales service at aftersaleservice@samsongroup.com.

Addresses of SAMSON AG and its subsidiaries

The addresses of SAMSON, its subsidiaries, representatives and service facilities worldwide can be found on our website (▶ www.samsongroup.com) or in all SAMSON product catalogs.

Required specifications

Please submit the following details:

- Device type and nominal size
- Valve balanced by a bellows or diaphragm
- Model number or material number
- Upstream and downstream pressure
- Temperature and process medium
- Min. and max. flow rate in m³/h
- Is a strainer installed?
- Installation drawing showing the exact location of the regulator and all the additionally installed components (shut-off valves, pressure gauge etc.)

EB 3003 EN



SAMSON AKTIENGESELLSCHAFT
Weismüllerstraße 3 · 60314 Frankfurt am Main, Germany
Phone: +49 69 4009-0 · Fax: +49 69 4009-1507
samson@samsongroup.com · www.samsongroup.com